



**WEB:** [www.yorkville.com](http://www.yorkville.com)

#### **WORLD HEADQUARTERS**

##### **CANADA**

**Yorkville Sound Limited**  
550 Granite Court  
Pickering, Ontario  
L1W 3Y8 CANADA

Voice: 905-837-8481  
Fax: 905-837-8746

##### **U.S.A.**

**Yorkville Sound Inc.**  
4625 Witmer Industrial Estate  
Niagara Falls, New York  
14305, USA

Voice: 716-297-2920  
Fax: 716-297-3689



# ***SERVICE MANUAL***

## ***Synergy SA 115S***

#### **SMT Disclaimer**

Due to the complex nature of the use of SMT installed components in Yorkville equipment, we highly caution all service technicians in attempting to repair or replace SMT factory installed components.

Many of these components may be glued prior to initial soldering.

**Replacing SMT components requires expensive specialized de-soldering equipment and training.**

Yorkville Sound will repair and replace defective SMT components to ensure proper quality assurance and installation is maintained.

**Quality and Innovation Since 1963**  
Printed in Canada

## IMPORTANT SAFETY INSTRUCTIONS



This lightning flash with arrowhead symbol, within an equilateral triangle, is intended to alert the user to the presence of uninsulated "dangerous voltage" within the product's enclosure that may be of sufficient magnitude to constitute a risk of electric shock to persons.

Ce symbole d'éclair avec tête de flèche dans un triangle équilatéral est prévu pour alerter l'utilisateur de la présence d'un «voltage dangereux» non-isolé à proximité de l'enceinte du produit qui pourrait être d'ampleur suffisante pour présenter un risque de choc électrique.



The DO NOT STACK symbol is intended to alert the user that the product shall not be vertically stacked because of the nature of the product.

La symbole NE PAS EMPIILER est pour alerter l'utilisateur que le produit ne doit pas être empilé verticalement en raison de la nature du produit.



### CAUTION • AVIS

**RISK OF ELECTRIC SHOCK  
DO NOT OPEN  
RISQUE DE CHOC ELECTRIQUE  
NE PAS OUVRIR**



**DO NOT  
PUSH OR PULL**



The exclamation point within an equilateral triangle is intended to alert the user to the presence of important operating and maintenance (servicing) instructions in the literature accompanying the appliance.

Le point d'exclamation à l'intérieur d'un triangle équilatéral est prévu pour alerter l'utilisateur de la présence d'instructions importantes dans la littérature accompagnant l'appareil en ce qui concerne l'opération et la maintenance de cet appareil.



**SEPARATE  
COLLECTION  
WEEE**



**CAUTION: HOT SURFACE  
ATTENTION: SURFACE CHAUDE**



**NOT TO BE SERVICED  
BY USERS**

### FOLLOW ALL INSTRUCTIONS

**Instructions pertaining to a risk of fire, electric shock, or injury to a person**

**CAUTION: TO REDUCE THE RISK OF ELECTRIC SHOCK, DO NOT REMOVE COVER (OR BACK).**

**NO USER SERVICEABLE PARTS INSIDE. REFER SERVICING TO QUALIFIED SERVICE PERSONNEL. THIS DEVICE IS FOR INDOOR USE ONLY!**

**INSTALLED BATTERY PACKS SHALL NOT BE EXPOSED TO EXCESSIVE HEAT**

**SUCH AS SUNSHINE, FIRE OR THE LIKE.**

### SUIVEZ TOUTES LES INSTRUCTIONS

**Instructions relatives au risque de feu, choc électrique, ou blessures aux personnes**

**AVIS: AFIN DE REDUIRE LES RISQUE DE CHOC ELECTRIQUE, N'ENLEVEZ PAS LE COUVERT (OU**

**LE PANNEAU ARRIERE) NE CONTIENT AUCUNE PIECE REPARABLE PAR L'UTILISATEUR.**

**CONSULTEZ UN TECHNICIEN QUALIFIE POUR L'ENTRETIEN CE PRODUIT EST POUR L'USAGE A**

**L'INTERIEUR SEULEMENT. LES PACKS BATTERIES INSTALLEES NE DOIVENT PAS ETRE EXPOSES**

**A UNE CHALEUR EXCESSIVE TELLE QUE LE ENSOLEILLEMENT, LE FEU OU SIMILAIRES.**

**Read Instructions:** The Owner's Manual should be read and understood before operation of your unit. Please, save these instructions for future reference and heed all warnings.

Clean only with dry cloth.

**Packaging:** Keep the box and packaging materials, in case the unit needs to be returned for service.

**Warning:** To reduce the risk of fire or electric shock, do not expose this apparatus to rain or moisture. *Do not use this apparatus near water!*

**Warning:** When using electric products, basic precautions should always be followed, including the following:

#### Power Sources

Your unit should be connected to a power source only of the voltage specified in the owners manual or as marked on the unit. This unit has a polarized plug. Do not use with an extension cord or receptacle unless the plug can be fully inserted. Precautions should be taken so that the grounding scheme on the unit is not defeated. An apparatus with CLASS I construction shall be connected to a Mains socket outlet with a protective earthing connection. Where the MAINS plug or an appliance coupler is used as the disconnect device, the disconnect device shall remain readily operable.

#### Hazards

Do not place this product on an unstable cart, stand, tripod, bracket or table. The product may fall, causing serious personal injury and serious damage to the product. Use only with cart, stand, tripod, bracket, or table recommended by the manufacturer or sold with the product. Follow the manufacturer's instructions when installing the product and use mounting accessories recommended by the manufacturer. Only use attachments/accessories specified by the manufacturer. Note: Prolonged use of headphones at a high volume may cause health damage on your ears.

The apparatus should not be exposed to dripping or splashing water; no objects filled with liquids should be placed on the apparatus.

Terminals marked with the "lightning bolt" are hazardous live; the external wiring connected to these terminals require installation by an instructed person or the use of ready made leads or cords.

Ensure that proper ventilation is provided around the appliance. Do not install near any heat sources such as radiators, heat registers, stoves, or other apparatus (including amplifiers) that produce heat.

No naked flame sources, such as lighted candles, should be placed on the apparatus.

#### Power Cord

Do not defeat the safety purpose of the polarized or grounding-type plug. A polarized plug has two blades with one wider than the other. A grounding type plug has two blades and a third grounding prong. The wide blade or the third prong are provided for your safety. If the provided plug does not fit into your outlet, consult an electrician for replacement of the obsolete outlet. The AC supply cord should be routed so that it is unlikely that it will be damaged. Protect the power cord from being walked on or pinched particularly at plugs. If the AC supply cord is damaged DO NOT OPERATE THE UNIT. To completely disconnect this apparatus from the AC Mains, disconnect the power supply cord plug from the AC receptacle. The mains plug of the power supply cord shall remain readily operable.

Unplug this apparatus during lightning storms or when unused for long periods of time.

#### Service

The unit should be serviced only by qualified service personnel. Servicing is required when the apparatus has been damaged in any way, such as power-supply cord or plug is damaged, liquid has been spilled or objects have fallen into the apparatus, the apparatus has been exposed to rain or moisture, does not operate normally, or has been dropped. Disconnect power before servicing!

**Veillez Lire le Manuel:** Il contient des informations qui devraient étre comprises avant l'opération de votre appareil.

Conservez. Gardez S.V.P. ces instructions pour consultations ultérieures et observez tous les avertissements.

Nettoyez seulement avec le tissu sec.

**Emballage:** Conservez la boîte au cas où l'appareil devait étre retourner pour réparation.

**Avertissement:** Pour réduire le risque de feu ou la décharge électrique, n'exposez pas cet appareil à la pluie ou à l'humidité. *N'utilisez pas cet appareil près de l'eau!*

**Attention:** Lors de l'utilisation de produits électrique, assurez-vous d'adhérer à des précautions de bases incluant celle qui suivent:

**Alimentation** - L'appareil ne doit étre branché qu'à une source d'alimentation correspondant au voltage spécifié dans le manuel ou tel qu'indiqué sur l'appareil. Cet appareil est équipé d'une prise d'alimentation polarisée. Ne pas utiliser cet appareil avec un cordon de raccordement à moins qu'il soit possible d'insérer complètement les trois lames. Des précautions doivent étre prises afin d'éviter que le système de mise à la terre de l'appareil ne soit désengagé. Un appareil construit selon les normes de CLASS I devrait étre raccordé à une prise murale d'alimentation avec connexion intacte de mise à la masse. Lorsqu'une prise de branchement ou un coupleur d'appareils est utilisée comme dispositif de débranchement, ce dispositif de débranchement devra demeurer pleinement fonctionnel avec raccordement à la masse.

**Risque** - Ne pas placer cet appareil sur un chariot, un support, un trépied ou une table instables. L'appareil pourrait tomber et blesser quelqu'un ou subir des dommages importants. Utiliser seulement un chariot, un support, un trépied ou une table recommandés par le fabricant ou vendus avec le produit. Suivre les instructions du fabricant pour installer l'appareil et utiliser les accessoires recommandés par le fabricant. Utilisez seulement les accessoires/accessoires indiqués par le fabricant. Note: L'utilisation prolongée des écouteurs à un volume élevé peut avoir des conséquences néfastes sur la santé sur vos oreilles.

Il convient de ne pas placer sur l'appareil de sources de flammes nues, telles que des bougies allumées.

L'appareil ne doit pas étre exposé à des égouttements d'eau ou des éclaboussures et qu'aucun objet rempli de liquide tel que des vases ne doit étre placé sur l'appareil.

Assurez que l'appareil est fourni de la propre ventilation. Ne procédez pas à l'installation près de source de chaleur tels que radiateurs, registre de chaleur, fours ou autres appareils (incluant les amplificateurs) qui produisent de la chaleur.

Les dispositifs marqués d'une symbole "d'éclair" sont des parties dangereuses au toucher et que les câblages extérieurs connectés à ces dispositifs de connection extérieure doivent étre effectués par un opérateur formé ou en utilisant des cordons déjà préparés.

**Cordon d'Alimentation** - Ne pas enlever le dispositif de sécurité sur la prise polarisée ou la prise avec tige de mise à la masse du cordon d'alimentation. Une prise polarisée dispose de deux lames dont une plus large que l'autre. Une prise avec tige de mise à la masse dispose de deux lames en plus d'une troisième tige qui connecte à la masse. La lame plus large ou la tige de mise à la masse est prévu pour votre sécurité. La prise murale est désuète si elle n'est pas conçue pour accepter ce type de prise avec dispositif de sécurité. Dans ce cas, contactez un électricien pour faire remplacer la prise murale. Évitez d'endommager le cordon d'alimentation. Protégez le cordon d'alimentation. Assurez-vous qu'on ne marche pas dessus et qu'on ne le pince pas en particulier aux prises. N'UTILISEZ PAS L'APPAREIL si le cordon d'alimentation est endommagé. Pour débrancher complètement cet appareil de l'alimentation CA principale, déconnectez le cordon d'alimentation de la prise d'alimentation murale. Le cordon d'alimentation du bloc d'alimentation de l'appareil doit demeurer pleinement fonctionnel.

Débranchez cet appareil durant les orages ou si inutilisé pendant de longues périodes.

**Service** - Consultez un technicien qualifié pour l'entretien de votre appareil. L'entretien est nécessaire quand l'appareil a été endommagé de quelque façon que se soit. Par exemple si le cordon d'alimentation ou la prise du cordon sont endommagés, si il y a eu du liquide qui a été renversé à l'intérieur ou des objets sont tombés dans l'appareil, si l'appareil a été exposé à la pluie ou à l'humidité, si il ne fonctionne pas normalement, ou a été échappé. Débrancher l'appareil avant d'enlever les couvercles!

## IMPORTANT SAFETY INSTRUCTIONS



The Lightning Flash with arrowhead symbol within an equilateral triangle, is intended to alert the user to the presence of uninsulated "dangerous voltage" within the product enclosure that may be of sufficient magnitude to constitute a risk of shock to persons



The exclamation point within an equilateral triangle is intended to alert the user to the presence of important operating and maintenance (servicing) instructions in the literature accompanying the product

1. Read these instructions.
2. Keep these instructions.
3. Heed all warnings.
4. Follow all instructions.
5. Do not use this apparatus near water.
6. Clean only with dry cloth.
7. Do not block any ventilation openings. Install in accordance with the manufacturer's instructions.
8. Do not install near any heat sources such as radiators, heat registers, stoves, or other apparatus (including amplifiers) that produce heat.
9. Do not defeat the safety purpose of the polarized or grounding-type plug. A polarized plug has two blades with one wider than the other. A grounding type plug has two blades and a third grounding prong. The wide blade or the third prongs are provided for your safety. If the provided plug does not fit into your outlet, consult an electrician for replacement of the obsolete outlet.
10. Protect the power cord from being walked on or pinched particularly at plugs, convenience receptacles, and the point where they exit from the apparatus.
11. Only use attachments/accessories specified by the manufacturer.
12. Use only with the cart, stand, tripod, bracket, or table specified by the manufacturer, or sold with the apparatus. When a cart is used, use caution when moving the cart/apparatus combination to avoid injury from tip-over.
13. Unplug this apparatus during lightning storms or when unused for long periods of time.

14. Refer all servicing to qualified service personnel. Servicing is required when the apparatus has been damaged in any way, such as power-supply cord or plug is damaged, liquid has been spilled or objects have fallen into the apparatus, the apparatus has been exposed to rain or moisture, does not operate normally, or has been dropped.

#### WARNING:

- To reduce the risk of fire or electric shock, do not expose this apparatus to rain or moisture and objects filled with liquids, such as vases, should not be placed on this apparatus.
- To completely disconnect this apparatus from the ac mains, disconnect the power supply cord plug from the ac receptacle.
- The mains plug of the power supply cord or appliance coupler shall remain readily accessible.



Le symbole représentant un éclair avec une flèche à l'intérieur d'un triangle équilatéral est utilisé pour prévenir l'utilisateur de la présence d'une tension électrique dangereuse non isolée à l'intérieur de l'appareil. Cette tension est d'un niveau suffisamment élevé pour représenter un risque d'électrocution



Le symbole représentant un point d'exclamation à l'intérieur d'un triangle équilatéral, signale à l'utilisateur la présence d'instructions importantes relatives au fonctionnement et à l'entretien de l'appareil dans cette notice d'installation

1. Lisez ces instructions.
2. Conservez ces instructions.
3. Respecter tous les avertissements.
4. Suivez toutes les instructions.
5. N'utilisez pas l'appareil près de l'eau.
6. Nettoyer uniquement avec chiffon sec.
7. Ne bloquez pas les ouvertures de ventilation. Installer en suivant les instructions du fabricant.
8. Ne pas installer près des sources de chaleur telles que radiateurs, bouches de chaleur, four ou autres appareils (y compris les amplificateurs) produisant de la chaleur.
9. N'annulez pas l'objectif sécuritaire de la fiche polarisée ou de la tige de mise à la terre. Une fiche polarisée possède deux lames avec une plus large que l'autre. Une prise avec mise à la terre possède deux lames et une troisième tige. La lame large ou la troisième tige sont fournis pour votre sécurité. Si la fiche n'entre pas dans votre prise, consultez un électricien pour remplacer la prise obsolète.
10. Protéger le cordon d'alimentation des piétinements ou pincements en particulier près des fiches, des prises de courant et au point de sortie de l'appareil.
11. Utilisez uniquement les accessoires spécifiés par le fabricant.
12. Utiliser uniquement avec un charriot, stand, trépied ou une table spécifiée par le fabricant, ou vendus avec l'appareil.
13. Débranchez l'appareil durant un orage ou lorsqu'il reste inutilisé pendant de longues périodes de temps.
14. Confiez toute réparation à un technicien qualifié. Une réparation est nécessaire lorsque l'appareil a été endommagé de quelque façon que ce soit; comme lorsque le cordon d'alimentation ou la fiche est endommagé, lorsque du liquide a été renversé ou des objets sont tombés à l'intérieur, lorsque l'appareil a été exposé à la pluie ou l'humidité, ne fonctionne pas normalement, ou est tombé.

#### AVERTISSEMENT:

- Pour réduire les risques d'incendie ou de choc électrique, ne pas exposer cet appareil à la pluie ou à l'humidité et ne placez pas d'objets contenant des liquides, tels que des vases, sur l'appareil.
- Pour isoler totalement cet appareil de l'alimentation secteur, débranchez totalement son cordon d'alimentation du réceptacle CA.
- La prise du cordon d'alimentation ou du prolongateur, si vous en utilisez un comme dispositif de débranchement, doit rester facilement accessible

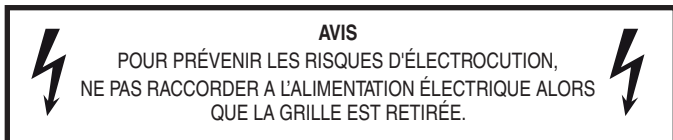
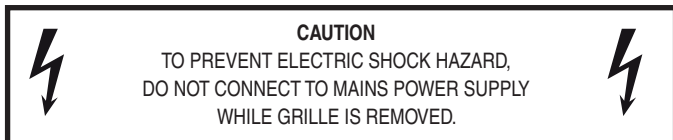

ALL CONNECTED IN PARALLEL

Pwr

Activity

Input Clip

X-MAX Limit

VC Therm

Sub Level Control: -24, -12, -6, 0, 2, 4, 6, 8

SUB LEVEL dB

Line Current Limit Control: 2, 3, 4, 5

AMPs

LINE CURRENT LIMIT

5A = MAX Output  
4A = 90% Output  
3A = 80% Output  
2A = 60% Output



**SYNERGY**  
ACTIVE SUBWOOFER  
**SA115S**



CAUTION - TO REDUCE THE RISK OF ELECTRIC SHOCK, GROUNDING OF THE CENTRE PIN OF THIS PLUG MUST BE MAINTAINED!  
ATTENTION - POUR RÉDUIRE LE RISQUE DE CHOC ÉLECTRIQUE, CONSERVER LA MISE À LA TERRE ASSURÉE PAR LA TIGE CENTRALE DE CETTE FICHE!

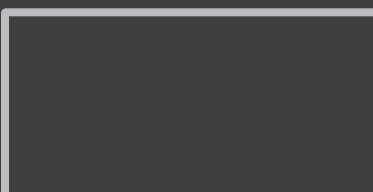

DISCONNECT POWER BEFORE SERVICING!  
DEBRANCHER L'APPAREIL AVANT D'ENLEVER LES COUVERCLES!

NO USER SERVICEABLE PARTS INSIDE.  
NE CONTIENT AUCUNE PIÈCE RÉPARABLE PAR L'UTILISATEUR.

SA115S A-21810 / 1v4



DESIGNED & MANUFACTURED BY  
YORKVILLE SOUND • TORONTO, CANADA

CAUTION: THIS EQUIPMENT REQUIRES A 15A LINE CORD  
ATTENTION: CET ÉQUIPEMENT NECESSITE UN CORDON DE LIGNE 15A

120V~60Hz  
3A STANDALONE  
12A MAX WITH  
AC OUTLET

9A MAX ON  
FIRST OUTLET  
SEE OWNERS MANUAL FOR  
CASCADE INSTALLATION

Circuit  
Breaker



POWER  
On



Off



### Specifications

System Type	Active Subwoofer
Active or Passive	Active
Program Power (watts)	4500 watts Program (9000 watts peak)
Measured Max SPL (C-Weighted, Max Hold)	129dB Cont. 135 dB Peak
Frequency Response (Hz +/- 3dB)	31 Hz - 100 Hz
Crossover Frequency (Hz)	100 Hz lowpass
Cabinet Configuration	Tapped Horn
Driver Configuration	1x15-inch LF woofer
LF Driver(s)	15-inch Neodymium with 4.5-inch Voice Coil
LF Program Power (watts)	4500 watts program (9000 watts peak)
LF Impedance (ohms)	4 ohm Load
LF Protection	Excursion, Voice Coil Thermal (RMS)
LF Amplifier Type	Class D
Cooling Scheme	Convection
Power Cable	Removable Locking Powercon True Input and Loop Thru Output
Power Switch	Yes
Inputs	1 XLR with 2x XLR Parallel out, Impedance 35k ohms
Input Sensitivity (Vrms Sine)	Line in 1.4 at center, 0.56 at max
Level Controls	Volume, -∞,0dB,8dB (Min, Top, Max)
EQ Controls	Thermal Limiter Advance for power consumption management
Limiter	Excursion, Thermal (RMS), Clipping
LED Indicators	Power, Excursion Limit, Thermal (RMS) Limit, Input Clip, Activity
Enclosure Materials	Multiply 15mm Birch Plywood
Stacking Feature	Interlocking Rubber Feet (Sides)
Covering / Finish	Paint
Dimensions (DWH xbackW, inches)	36.625 (including Casters) x 17.750 x 35.250
Dimensions (DWH xbackW, cm)	93 x 45 x 82
Weight (lbs/kg)	165/74.9

*\*Specifications subject to change without notice*

### Spécifications

Type de système	Caisson de Basse actif
Actif ou passif	Actif
Puissance du programme (watts)	4500 watts Programme (9000 watts crête)
NPA maximum mesuré (pondéré C, maintien maximum)	129dB Cont. 135 dB crête
Réponse en fréquence (Hz +/- 3dB)	31 Hz - 100 Hz
Fréquence de coupure (Hz)	Passe-bas 100 Hz
Configuration de l'enceinte	Haut-parleur à pavillon
Configuration des haut-parleurs	1 haut-parleur de graves de 15 pouces
Driver(s) BF	Néodyme de 15 pouces avec bobine mobile de 4,5 pouces
Puissance nominale BF (watts)	4500 watts programme (9000 watts crête)
Impédance BF (ohms)	Charge de 4 ohms
Protection BF	Excursion, Thermique de la bobine mobile (RMS)
Type d'amplificateur BF	Classe D
Système de refroidissement	Convection
Cordon d'alimentation	Entrée Powercon True et sortie Loop Thru verrouillables et amovibles
Interrupteur d'alimentation	Oui
Entrées	1 XLR avec 2x XLR sortie parallèle, Impédance 35k ohms
Sensibilité d'entrée (Vrms sinus)	Entrée ligne 1,4 au centre, 0,56 au maximum
Commandes de niveau	Volume, -∞, 0dB, 8dB (Min, Top, Max)
Commandes d'égalisation	Limiteur thermique Advance pour la gestion de la consommation d'énergie
Limiteur	Excursion, thermique (RMS), écrêtage
Indicateurs DEL	Puissance, Limite d'excursion, Limite thermique (RMS), Clip d'entrée. Activité
Matériaux du boîtier	Contreplaqué de bouleau multiplis de 15 mm
Caractéristiques d'empilage	Pieds en caoutchouc emboîtables (côtés)
Revêtement / Finition	Peinture
Dimensions (PLH x L arrière, pouces)	36,625 (y compris les roulettes) x 17,750 x 35,250
Dimensions (PLH x L arrière, cm)	93 x 45 x 82
Poids (livres/kg)	165/74.9

*\*Spécifications sujettes à modification sans préavis*

# Block Diagram SA115S

DESIGNED & MANUFACTURED BY YORKVILLE SOUND

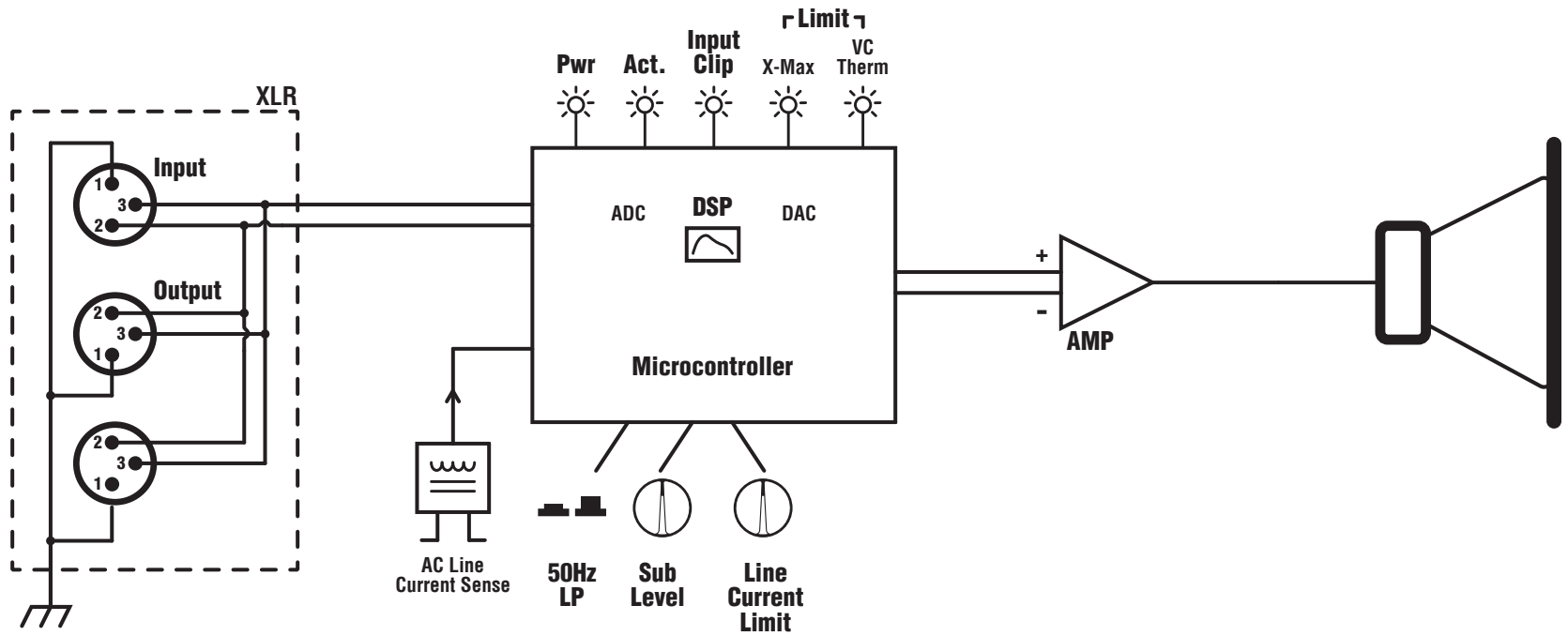









M1833-04 Parts Reference List 2023-03-17

REF	YS #	Description	REF	YS #	Description	REF	YS #	Description	REF	YS #	Description	REF	YS #	Description
A1-SUB	M1833-59	SA115S/SA221S AMP/SUPPLY PCB AI	D3		MURA260T3 600V 2A DIO 403D SMT	R10		W100 150R 5% 0805 SMT RES	R223		W100 6K98 1% 0805 SMT RES			
BLANK	M1833BLANK	3 OZ 2SD 83.6 SQIN 01PER SA115S/221	D4		ES1J 600V 1A0 DO214AC SMT SMA	R11		W125 187K 0.1% 0805 SMT RES	R224		W125 47R 5% 0805 SMT RES			
C1		150P 1000V 5%CAP 1206 SMT COG	D5		ES1J 600V 1A0 DO214AC SMT SMA	R12		W125 187K 0.1% 0805 SMT RES	R225		W250 22R 5% 1206 SMT RES			
C2		10U 16V 20%CAP 5X5.4 SMT NP	D6		MM3Z18VT1G 18V0 0W2 5% SMT ZEN	R13		W125 187K 0.1% 0805 SMT RES	R226		W100 15K0 1% 0805 SMT RES			
C3		3U3 140AC10%CAP BLK RAD POLYP FLM	D7		B0540 SOD123 SMT SCHTKY	R14		W125 187K 0.1% 0805 SMT RES	R227		W100 1M0 1% 0805 SMT RES			
C4		3U3 140AC10%CAP BLK RAD POLYP FLM	D8		B0540 SOD123 SMT SCHTKY	R15		W125 140K 1% 0805 SMT RES	R229		W100 1R0 5% 2512 SMT RES			
C5		1U0 50V 10%CAP 1206 SMT CER	D9		B0540 SOD123 SMT SCHTKY	R16		W250 1M0 1% 1206 SMT RES	R231		W100 1K0 1% 0805 SMT RES			
C6		22U 16V 20%CAP 5X5.5 SMT ELC	D10		B0540 SOD123 SMT SCHTKY	R17		W250 1M0 1% 1206 SMT RES	R232		W100 1K0 1% 0805 SMT RES			
C7		100N 50V 5%CAP 0805 SMT X7R	D11		MM3Z18VT1G 18V0 0W2 5% SMT ZEN	R18		W250 1M0 1% 1206 SMT RES	R233		W100 6K98 1% 0805 SMT RES			
C8		47U 35V 20%CAP 6.3MM SMT ELE	D12		BAV21WS 200V 0A2 SOD323 SMT	R19		W125 6K20 1% 0805 SMT RES	R234		W100 182K 1% 0805 SMT RES			
C9		4U7 50V 10%CAP 1210 SMT CER	D13		BAV21WS 200V 0A2 SOD323 SMT	R20		W125 33K 5% 0805 SMT RES	R236		W100 6K98 1% 0805 SMT RES			
C10	5217	22N 560V 10%CAP BLK RAD POLY FLM	D14		5237B 8V2 0W2 SOT-23 SMT ZEN	R21		W125 6K20 1% 0805 SMT RES	R237		W100 1R0 5% 2512 SMT RES			
C11		4U7 50V 10%CAP 1210 SMT CER	D15		CDSF4148 75V 0A15 1005 SMT	R22		W100 1M0 1% 0805 SMT RES	R238		W125 33R 5% 0805 SMT RES			
C12	5923	3300U 250V 10%CAP BLK 40X80MM 4PS	D16		5237B 8V2 0W2 SOT-23 SMT ZEN	R24		W125 4K7 5% 0805 SMT RES	R240		W125 470R 5% 0805 SMT RES			
C13	5923	3300U 250V 10%CAP BLK 40X80MM 4PS	D17		5237B 8V2 0W2 SOT-23 SMT ZEN	R25		W100 10K0 1% 0805 SMT RES	R242		2W00 0R02 1% OARS SMT RES			
C14	5923	3300U 250V 10%CAP BLK 40X80MM 4PS	D18		BZX84C43 43V0 0W3 5% SMT ZEN	R26		W100 475K 1% 0805 SMT RES	R243		2W00 0R02 1% OARS SMT RES			
C15	5923	3300U 250V 10%CAP BLK 40X80MM 4PS	D19		CDSF4148 75V 0A15 1005 SMT	R27		W100 475K 1% 0805 SMT RES	R244		2W00 0R05 1% OARS SMT RES			
C16		100N 50V 5%CAP 0805 SMT X7R	D20		MURA260T3 600V 2A DIO 403D SMT	R28		W100 475K 1% 0805 SMT RES	R247		W125 4K7 5% 0805 SMT RES			
C17		22U 16V 20%CAP 5X5.5 SMT ELC	D21		B0540 SOD123 SMT SCHTKY	R29		W250 1M0 1% 1206 SMT RES	R249		W100 1R0 5% 2512 SMT RES			
C18		470N 100V 10%CAP 1206 SMT X7R	D22		B0540 SOD123 SMT SCHTKY	R30		W125 1K27 1% 0805 SMT RES	R251		W250 22R 5% 1206 SMT RES			
C19		680P 50V 5%CAP 0805 SMT COG	D23		MM3Z18VT1G 18V0 0W2 5% SMT ZEN	R31		W100 475K 1% 0805 SMT RES	R255		W125 82K5 1% 0805 SMT RES			
C20		220N 50V 10%CAP 1206 SMT X7R	D24		MM3Z18VT1G 18V0 0W2 5% SMT ZEN	R32		W100 475K 1% 0805 SMT RES	R256		W125 82K5 1% 0805 SMT RES			
C21		100N 100V 10%CAP 1206 SMT X7R	D25		MM3Z18VT1G 18V0 0W2 5% SMT ZEN	R33		W100 475K 1% 0805 SMT RES	R258		W100 20K5 1% 0805 SMT RES			
C22		100N 100V 10%CAP 1206 SMT X7R	D28		BZX84C43 43V0 0W3 5% SMT ZEN	R34		W100 475K 1% 0805 SMT RES	R259		W100 182K 1% 0805 SMT RES			
C23		33N 630V 5%CAP 1210 SMT COG	D204		ES1J 600V 1A0 DO214AC SMT SMA	R35		W125 33K 5% 0805 SMT RES	R260		470K 5% THERMISTOR NTC 0805 SMT			
C24		4U7 50V 10%CAP 1210 SMT CER	D205		ES1J 600V 1A0 DO214AC SMT SMA	R36		W100 475K 1% 0805 SMT RES	R261		W100 274K 1% 0805 SMT RES			
C25		4U7 50V 10%CAP 1210 SMT CER	D213		BZX84C15LT1 15V0 0W225 ZEN SOT23	R37		W100 475K 1% 0805 SMT RES	R262		W100 1M0 1% 0805 SMT RES			
C26		4U7 50V 10%CAP 1210 SMT CER	D214		CDSF4148 75V 0A15 1005 SMT	R38		W100 2K0 1% 0805 SMT RES	R268		W125 4K02 0.1% 0805 SMT RES			
C27		33N 630V 5%CAP 1210 SMT COG	F5		FUSE 1A25 500VDC SMT F4319	R39		W100 1M0 1% 0805 SMT RES	SNL1	8370	1 MIL POLYIMIDE LABEL, 1" X .380"			
C28		33N 630V 5%CAP 1210 SMT COG	F6		FUSE 1A25 500VDC SMT F4319	R40		W125 10R0 1% 0805 SMT RES	T4		XF3955 GATE DRIVE XFMR SMT			
C29		33N 630V 5%CAP 1210 SMT COG	HS1	4233	22X17X2MM ALN CERAMIC TO247 INSUL	R41		W100 1K0 1% 0805 SMT RES	T5		XF3955 GATE DRIVE XFMR SMT			
C30		100N 100V 10%CAP 1206 SMT X7R	HS2	4233	22X17X2MM ALN CERAMIC TO247 INSUL	R42		W100 475K 1% 0805 SMT RES	U1		LNK306G OFFLINE SWITCH SMT SMD8B			
C31		4U7 50V 10%CAP 1210 SMT CER	HS3	Z1740	M1806 HEAT SPREADER	R43		W100 475K 1% 0805 SMT RES	U2		LM393D DUAL COMPARATOR SMT SO-8			
C32		33N 630V 5%CAP 1210 SMT COG	HW1	8800	6-32 KEPS NUT ZINC	R44		W100 475K 1% 0805 SMT RES	U3		ZXGD3006E6Q GATE DRVR 10A SMT SOT26			
C33		33N 630V 5%CAP 1210 SMT COG	HW2	8902	4-40X3/4 PAN PHILIPS MS TBZ	R45		W100 475K 1% 0805 SMT RES	U4		ZXGD3006E6Q GATE DRVR 10A SMT SOT26			
C34		33N 630V 5%CAP 1210 SMT COG	HW4	8485	#6 SPLIT WASHER ZINC	R46		W100 475K 1% 0805 SMT RES	U5		TLC555 TIMER SMT SO8 IC			
C35		33N 630V 5%CAP 1210 SMT COG	HW6	8742	4-40X3/8 PAN PH TAPTITE BO&W	R47		W125 28K7 1% 0805 SMT RES	U8		UCC25600 RES MODE CTRL SMT SO8			
C36		33N 630V 5%CAP 1210 SMT COG	HW7	8835	6-32X1/2 PAN QUAD MS TIN PLATE	R48		W100 475K 1% 0805 SMT RES	U200		LTV-8141S ACINPUT OPTOCOUPLER SMT			
C37		100N 100V 10%CAP 1206 SMT X7R	HW8	8835	6-32X1/2 PAN QUAD MS TIN PLATE	R49		W125 4M7 5% 0805 SMT RES	U201		LM311 COMPARATOR IC SMT SO-8			
C38		10U 16V 10%CAP 1206 SMT X7R	HW9	8800	6-32 KEPS NUT ZINC	R50		W100 1M0 1% 0805 SMT RES	U202		LM311 COMPARATOR IC SMT SO-8			
C39		10U 16V 10%CAP 1206 SMT X7R	HW10	8902	4-40X3/4 PAN PHILIPS MS TBZ	R51		W125 100K0 1% 0805 SMT RES	U203		IRS21844SPBF IC HILO FET DRVR SO14			
C41		100N 100V 10%CAP 1206 SMT X7R	HW11	4124	SILPAD 1500ST 1.100 X0.820 BERQUIST	R53		W250 10K 5% ANTISURGE 0805 SMT RES	U204		33078 DUAL OPAMP SMT SO-8			
C42		1N 50V 5%CAP 0805 SMT NPO	HW12	4249	1POS XSISTOR SPRING	R54		W100 1M0 1% 0805 SMT RES	U205		33078 DUAL OPAMP SMT SO-8			
C43		1N 50V 5%CAP 0805 SMT NPO	HW13	8701	4-40 KEPS NUT ZINC	R55		W125 49K9 1% 0805 SMT RES	U206		TL331 COMPARATOR IC SMT SOT235			
C200		100N 50V 5%CAP 0805 SMT X7R	HW14	8701	4-40 KEPS NUT ZINC	R56		W125 49K9 1% 0805 SMT RES	W1	3538	24 PIN BREAKAWAY LOCK .156			
C202		100N 50V 5%CAP 0805 SMT X7R	HW15	8832	6-32X1/4 PAN PH TAPTITE JS500	R57		W125 49K9 1% 0805 SMT RES	W2	3538	24 PIN BREAKAWAY LOCK .156			
C203		100N 50V 5%CAP 0805 SMT X7R	HW17	8485	#6 SPLIT WASHER ZINC	R58		W125 49K9 1% 0805 SMT RES	W3	4146	3 PIN POWER PIN HEADER MALE POLZED			
C204		100N 50V 5%CAP 0805 SMT X7R	L1		120.0UH COIL A34 1R6 SMT	R59	4703	2W00 2R 5% T&R RES	W4	4163	5 PIN POWER PIN HEADER MALE POLZED			
C205		100N 50V 5%CAP 0805 SMT X7R	L2		1000UH 10% COIL 12MM SMT	R60	4703	2W00 2R 5% T&R RES	W5	3538	24 PIN BREAKAWAY LOCK .156			
C206		100N 50V 5%CAP 0805 SMT X7R	L3		120.0UH COIL A34 1R6 SMT	R61		W250 619K 1% 1206 SMT RES	W201	2328	8 CIR XH-HEADER 0.098IN			
C207		100N 50V 5%CAP 0805 SMT X7R	L4		0.18UH 20% COIL 11MM SMT	R62		W250 619K 1% 1206 SMT RES	ZD200		MM3Z18VT1G 18V0 0W2 5% SMT ZEN			
C208		100N 50V 5%CAP 0805 SMT X7R	L7		15.0UH COIL 0805 SMT	R63		W250 619K 1% 1206 SMT RES						
C209		100N 50V 5%CAP 0805 SMT X7R	L200	6699	453UH CHOKE 91T14.5AWG/79912CORE	R64		W125 100K 5% 0805 SMT RES						
C210		100N 50V 5%CAP 0805 SMT X7R	Q1		T810-600G-TR 8A TRIAC D2PAK SMT	R65		W125 100K 5% 0805 SMT RES						
C211		100N 50V 5%CAP 0805 SMT X7R	Q2		TL431A 3 TERM ADJ VREG SMT SOT-23	R66		W125 100K 5% 0805 SMT RES						
C212		100N 50V 5%CAP 0805 SMT X7R	Q3	5190	MBS4992 T092 8V5 DIAC T&R	R67		W100 475K 1% 0805 SMT RES						
C213		680P 50V 1%CAP 0805 SMT COG	Q4	6730	IRF830 TO220 NCH MFET TN	R70		W125 1K27 1% 0805 SMT RES						
C216		1N 50V 5%CAP 0805 SMT NPO	Q5		MMBTA42 NPN SOT-23 SMT	R71		W100 475K 1% 0805 SMT RES						
C217		470P 50V 5%CAP 0603 SMT NPO	Q6		MMBTA42 NPN SOT-23 SMT	R72		W100 1K0 1% 0805 SMT RES						
C218		1N 50V 5%CAP 0805 SMT NPO	Q7		MMBTA92 PNP SOT-23 SMT	R73		W250 33R 5% 1206 SMT RES						
C219	5972	680N 400V 5%CAP BLK RAD POLY FLM	Q8		2N7002 NCH FET SOT-23 SMT T&R	R74		W250 33R 5% 1206 SMT RES						
C220		220N 50V 10%CAP 1206 SMT X7R	Q9		MMBTA42 NPN SOT-23 SMT	R75		W125 100K 5% 0805 SMT RES						
C221		100N 100V 10%CAP 1206 SMT X7R	Q10		MMBTA92 PNP SOT-23 SMT	R76		W100 475K 1% 0805 SMT RES						
C222	5986	10U 500VDC 5%CAP BLK MPOLYP FLM	Q11		FDT3612 NCH MFET SOT-223 SMT	R77		W100 475K 1% 0805 SMT RES						
C223	5986	10U 500VDC 5%CAP BLK MPOLYP FLM	Q12		FDT3612 NCH MFET SOT-223 SMT	R78		W100 475K 1% 0805 SMT RES						
C224		1U 50V 20%CAP 4.3X3.9 SMT ELC	Q13		MC7815BDTG POS REG SMT DPAK3	R79		W125 100K 5% 0805 SMT RES						
C225		470P 50V 5%CAP 0603 SMT NPO	Q14		MMBTA42 NPN SOT-23 SMT	R80		W125 100K 5% 0805 SMT RES						
C226		47N 100V 10%CAP 1206 SMT X7R	Q15		MMBTA42 NPN SOT-23 SMT	R81		W100 1M0 1% 0805 SMT RES						
C227		100N 50V 5%CAP 0805 SMT X7R	Q203	2321	IKW75N65EH5 T0247 NPN 75A IGB3	R200		W125 10R0 1% 0805 SMT RES						
C228	5972	680N 400V 5%CAP BLK RAD POLY FLM	Q204		MMBTA92 PNP SOT-23 SMT	R201		W100 12K1 1% 0603 SMT RES						
C229	5225	470P 1600V 20%CAP POLYPROP BULK	Q205	2321	IKW75N65EH5 T0247 NPN 75A IGB3	R202								





M1950-03 Parts Reference List 5/19/2021

REF	YS #	Description	REF	YS #	Description	REF	YS #	Description
AI-ASS	M1950-59	SA221S INPUT DSP BOARD 1OZ	LD6		GRN LED 2V8 20MA 1206 SMT	S1	3522	DPDT MINI PC VERT SNP ALT
C1		100N 50V 5%CAP 0805 SMT X7R	F4	2339	10K B LIN 12MM DUAL 21DET P34	S4	4189	DP4T NONSHORTING VERT ROT SWT
C2		470P 50V 5%CAP 0603 SMT NPO	PCB1	M1950BLANK	1 OZ 2SD 60.67SQIN 3PER SA221S INP	SNL2	8372	1 MIL POLYIMIDE LABEL...375" X .375"
C3		1U 25V 20%CAP 1206 SMT X7R	Q1		MMBT5401 PNP SOT-23 SMT	TP1		TEST POINT MINIATURE SMT
C4		100N 50V 5%CAP 0805 SMT X7R	Q2		MMBT5401 PNP SOT-23 SMT	TP7		TEST POINT MINIATURE SMT
C5		100N 50V 5%CAP 0805 SMT X7R	Q3		MMBT442 NPN SOT-23 SMT	TP8		TEST POINT MINIATURE SMT
C6	5669	470U 6V3 20%CAP RAD EL T&R	R1		W125 750R 1% 0805 SMT RES	TP9		TEST POINT MINIATURE SMT
C7	5945	10U 63V 20%CAP T&R RAD .2EL	R2		W100 3K74 1% 0805 SMT RES	TP10		TEST POINT MINIATURE SMT
C8	5945	10U 63V 20%CAP T&R RAD .2EL	R3		W125 1K21 1% 0805 SMT RES	TP12		TEST POINT MINIATURE SMT
C9	5233	330N 63V 5%CAP T&R RAD .2FLM	R4		W125 37K4 1% 0805 SMT RES	TP13		TEST POINT MINIATURE SMT
C10	5233	330N 63V 5%CAP T&R RAD .2FLM	R5		W125 22K1 1% 0805 SMT RES	TP14		TEST POINT MINIATURE SMT
C11	5212	100N 100V 5%CAP T&R RAD .2FLM	R6		W125 10K00 0.1% 0805 SMT RES	TP15		TEST POINT MINIATURE SMT
C12		100N 50V 5%CAP 0805 SMT X7R	R7		W100 499R 1% 0805 SMT RES	U1		33078 DUAL OPAMP SMT SO-8
C13		100N 50V 5%CAP 0805 SMT X7R	R8		W125 750R 1% 0805 SMT RES	U2		MC33063ADR BUCK/BOOST INV IC SO8
C14		100N 50V 5%CAP 0805 SMT X7R	R9		W100 499R 1% 0805 SMT RES	U3		AK4558 32BIT CODEC SMT QFN28
C15		100N 50V 5%CAP 0805 SMT X7R	R10		W125 1K5 5% 0805 SMT RES	U4		MK10DN512VLK10 100MHZ MCU IC LQFP80
C16	5212	100N 100V 5%CAP T&R RAD .2FLM	R11		W100 499R 1% 0805 SMT RES	U5	7012	LP2950-33 LDRP TO92 FIXED 3V3 REG
C17		10U 16V 10%CAP 1206 SMT X7R	R12		W125 10K00 0.1% 0805 SMT RES	U6	7012	LP2950-33 LDRP TO92 FIXED 3V3 REG
C18		10U 16V 20%CAP 0805 SMT X5R	R13		W100 200R 1% 0805 SMT RES	U7		TL072 DUAL OPAMP SMT SO-8
C19		100N 50V 5%CAP 0805 SMT X7R	R14		W125 750R 1% 0805 SMT RES	U8		TL072 DUAL OPAMP SMT SO-8
C20		100N 50V 5%CAP 0805 SMT X7R	R15		W250 0R27 5% 1206 SMT RES	U9		TL072 DUAL OPAMP SMT SO-8
C21		100N 50V 5%CAP 0805 SMT X7R	R16		W100 2K0 1% 0805 SMT RES	W1	2357	4 CIR XH-HEADER RA 0.098IN
C22		1U 25V 20%CAP 1206 SMT X7R	R17		W100 2K0 1% 0805 SMT RES	W2	2328	8 CIR XH-HEADER 0.098IN
C23		100N 50V 5%CAP 0805 SMT X7R	R18		W100 100R 1% 0805 SMT RES	W3		10 CIR DUAL ROW HDR 0.05 SPC SMT
C24		1U 25V 20%CAP 1206 SMT X7R	R19		W063 49R9 1% 0603 SMT RES	W4	2328	8 CIR XH-HEADER 0.098IN
C25		100N 50V 5%CAP 0805 SMT X7R	R20		W125 47R 5% 0805 SMT RES	W6	2369	3 CIR PH-HEADER 2MM
C26		1U 25V 20%CAP 1206 SMT X7R	R21		W100 100R 1% 0805 SMT RES	W8	4056	2 CIR XH-HEADER 0.098IN
C27		1U 25V 20%CAP 1206 SMT X7R	R22		W125 47K 5% 0805 SMT RES	ZD1		MM3Z18VT1G 18V0 0W2 5% SMT ZEN
C28		100N 50V 5%CAP 0805 SMT X7R	R23		W125 47K 5% 0805 SMT RES	ZD2		MM3Z18VT1G 18V0 0W2 5% SMT ZEN
C29		100N 50V 5%CAP 0805 SMT X7R	R24		W125 10K00 0.1% 0805 SMT RES			
C30		100N 50V 5%CAP 0805 SMT X7R	R25		W125 10K00 0.1% 0805 SMT RES			
C31		100N 50V 5%CAP 0805 SMT X7R	R26		W125 10K00 0.1% 0805 SMT RES			
C32		470P 50V 5%CAP 0603 SMT NPO	R27		W100 499R 1% 0805 SMT RES			
C33		470P 50V 5%CAP 0603 SMT NPO	R28		W125 47R5 1% 0805 SMT RES			
C34		100N 50V 5%CAP 0805 SMT X7R	R29		W125 4K7 5% 0805 SMT RES			
C35		1U 25V 20%CAP 1206 SMT X7R	R30		W100 2K32 1% 0805 SMT RES			
C36		1U 25V 20%CAP 1206 SMT X7R	R31		W125 10R0 1% 0805 SMT RES			
C37		470P 50V 5%CAP 0603 SMT NPO	R32		W125 10K00 0.1% 0805 SMT RES			
C38		100N 50V 5%CAP 0805 SMT X7R	R33		W100 100R 1% 0805 SMT RES			
C39		100N 50V 5%CAP 0805 SMT X7R	R35		W125 249R0 1% 0805 SMT RES			
C40		100P 50V 10%CAP 0805 SMT NPO	R36		W125 249R0 1% 0805 SMT RES			
C41	5212	100N 100V 5%CAP T&R RAD .2FLM	R37		W100 6K98 1% 0805 SMT RES			
C42	5212	100N 100V 5%CAP T&R RAD .2FLM	R38		W100 100R 1% 0805 SMT RES			
C43		20P 100V 5%CAP 0805 SMT NPO	R39		W125 47R5 1% 0805 SMT RES			
C44		20P 100V 5%CAP 0805 SMT NPO	R40		W125 0R 5% 0805 SMT RES			
C45		20P 100V 5%CAP 0805 SMT NPO	R41		W125 37K4 1% 0805 SMT RES			
C46		1U 25V 20%CAP 1206 SMT X7R	R42		W125 10R0 1% 0805 SMT RES			
C47		100N 50V 5%CAP 0805 SMT X7R	R44		W125 4K7 5% 0805 SMT RES			
C48		10U 16V 10%CAP 1206 SMT X7R	R45		W125 33R 5% 0805 SMT RES			
C49		10U 16V 10%CAP 1206 SMT X7R	R46		W125 33R 5% 0805 SMT RES			
C50		10U 16V 10%CAP 1206 SMT X7R	R47		W125 4K02 0.1% 0805 SMT RES			
C51		100P 50V 10%CAP 0805 SMT NPO	R48		W125 750R 1% 0805 SMT RES			
C52		100P 50V 10%CAP 0805 SMT NPO	R49		W125 750R 1% 0805 SMT RES			
C55		100U 25V 20%CAP 8X5.4 SMT ELE	R51		W125 47R 5% 0805 SMT RES			
C134		100N 50V 5%CAP 0805 SMT X7R	R52		W125 560R 5% 0805 SMT RES			
C135		100N 50V 5%CAP 0805 SMT X7R	R53		W100 2K0 1% 0805 SMT RES			
D1		B160-E3 60V 1A0 SCH DO214AC SMT	R54		W125 4K02 0.1% 0805 SMT RES			
D2		CDSF4148 75V 0A15 1005 SMT	R55		W125 560R 5% 0805 SMT RES			
D3		CDSF4148 75V 0A15 1005 SMT	R56		W100 200R 1% 0805 SMT RES			
D4		B160-E3 60V 1A0 SCH DO214AC SMT	R57		W100 2K0 1% 0805 SMT RES			
D5		MM3Z18VT1G 18V0 0W2 5% SMT ZEN	R58		W125 187K 0.1% 0805 SMT RES			
D6		CDSF4148 75V 0A15 1005 SMT	R59		W125 187K 0.1% 0805 SMT RES			
D7		CDSF4148 75V 0A15 1005 SMT	R62		W125 4K02 0.1% 0805 SMT RES			
D10		CDSF4148 75V 0A15 1005 SMT	R65		W125 4K02 0.1% 0805 SMT RES			
D11		CDSF4148 75V 0A15 1005 SMT	R66		W125 10K00 0.1% 0805 SMT RES			
D12		CDSF4148 75V 0A15 1005 SMT	R67		W125 10K00 0.1% 0805 SMT RES			
D39		CDSF4148 75V 0A15 1005 SMT	R68		W125 698R 1% 0805 SMT RES			
D40		CDSF4148 75V 0A15 1005 SMT	R69		W125 47K 5% 0805 SMT RES			
R1	3700	RELAY 2C 01AMP DC24 015MA PC-S	R70		W125 47K 5% 0805 SMT RES			
L2		15.0UH COIL 0805 SMT	R71		W125 33R 5% 0805 SMT RES			
L3		220UH COIL 10X10MM SMT	R72		W125 37K4 1% 0805 SMT RES			
L6		8.2UH COIL 1210 SMT	R73		W100 2K0 1% 0805 SMT RES			
L7		8.2UH COIL 1210 SMT	R75		W125 10K00 0.1% 0805 SMT RES			
L10		15.0UH COIL 0805 SMT	R76		W100 6K98 1% 0805 SMT RES			
L11		15.0UH COIL 0805 SMT	R107		W125 22K1 1% 0805 SMT RES			
L12		15.0UH COIL 0805 SMT	R165		W125 31K6 0.1% 0805 SMT RES			
LD1		GRN LED 2V8 20MA 1206 SMT	R176		W125 3K32 1% 0805 SMT RES			
LD2		YEL LED 1V7 20MA 1206 SMT	R177		W125 100K 5% 0805 SMT RES			
LD3		RED LED 1V5 20MA 1206 SMT	R178		W125 1K02 0.1% 0805 SMT RES			
LD4		YEL LED 1V7 20MA 1206 SMT	R181		W125 31K6 0.1% 0805 SMT RES			

## CAPACITOR DISCHARGE CIRCUIT

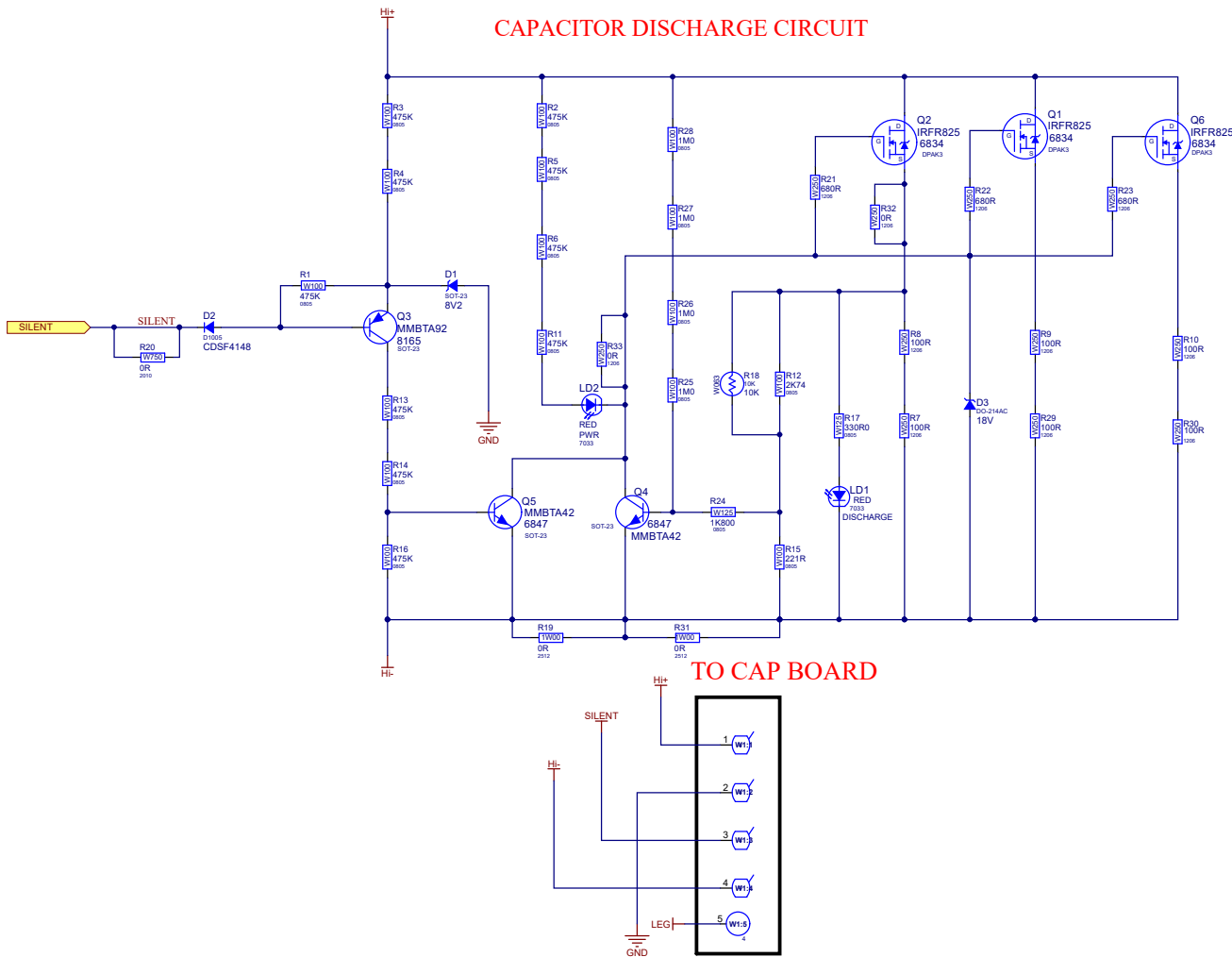

Yorkville Sound Ltd.  
550 Granite Court  
Pickering, ON  
Canada L1W 3Y8  
www.yorkville.com

Product(s):	<b>SA315S</b>			
Description:	Short Description Of The Product			
PCBR: M1811	Rev: V02	EML Rev: XX	Sheet 1	Of 2
Modified: 2019-03-20	File: Discharge_Circuit.SchDoc	Temp Rev: V031		



# SA315S M1811 V02

SINGLE LAYER  
1 OZ.PCB  
1.5mm ALUMINUM

DISCHARGE P.C.B.  
FROM CAPACITOR BOARD

LABEL  
S/N

DISCHARGE  
INDICATING LED

POWER ON  
INDICATING LED

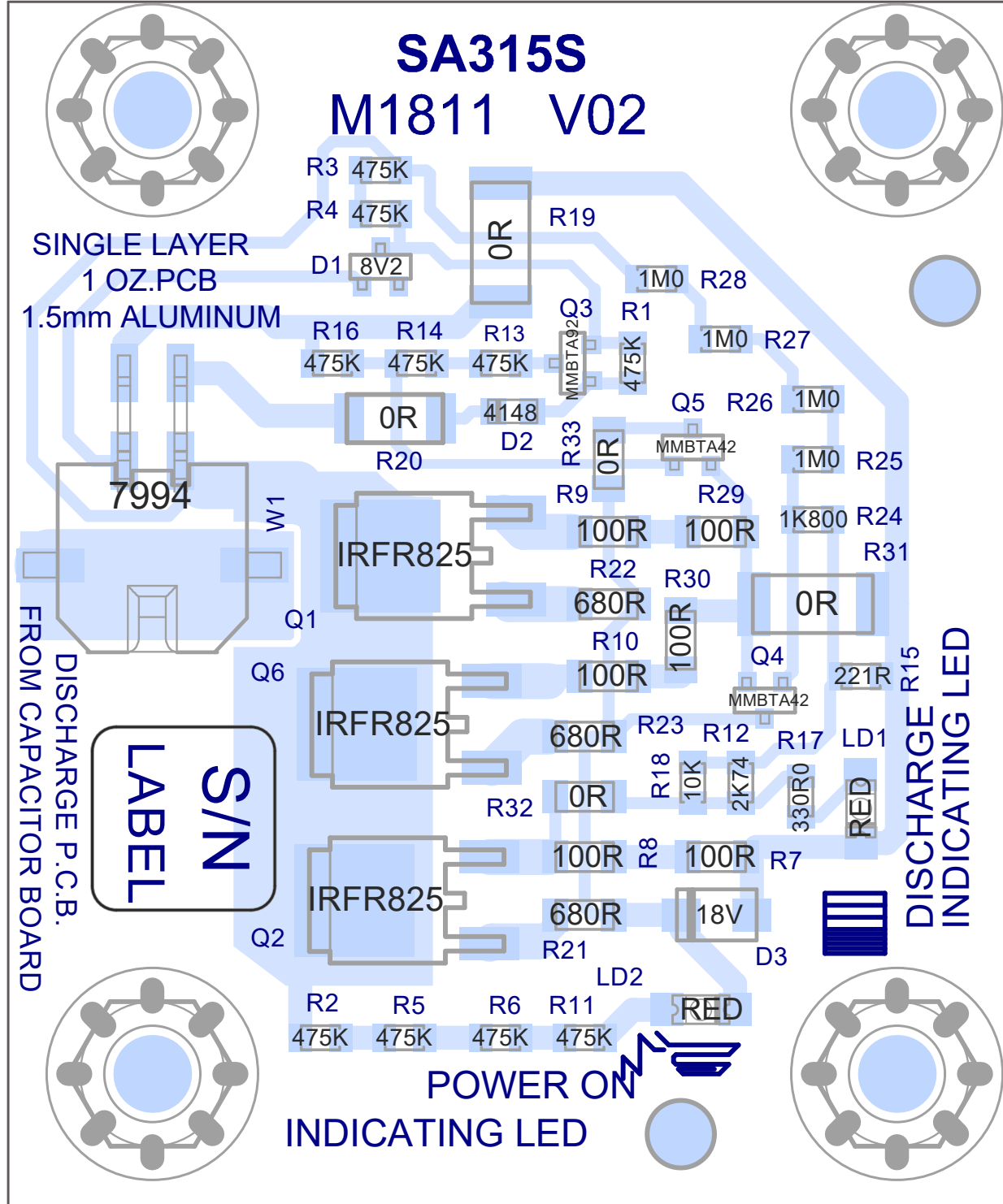



# PCB ASSEMBLY DOCUMENTATION

1. INSPECT SOLDER JOINTS AFTER REFLOW
2. USE PIZZA CUTTER TO SEPARATE BOARDS FROM PANEL.

	<b>Section:</b> Assembly Documentation			
	<b>Product(s):</b> SA315S			
	<b>PCB#:</b> M1811	<b>Rev#:</b> V02	<b>ENL Rev#:</b> XX	<b>Sheet</b> 2 <b>Of</b> 4
	<b>Modified:</b> 2019-03-20	<b>File:</b> Assembly.SchDoc		<b>Temp Rev:</b> V031



INPUT

THRU 1

THRU 2

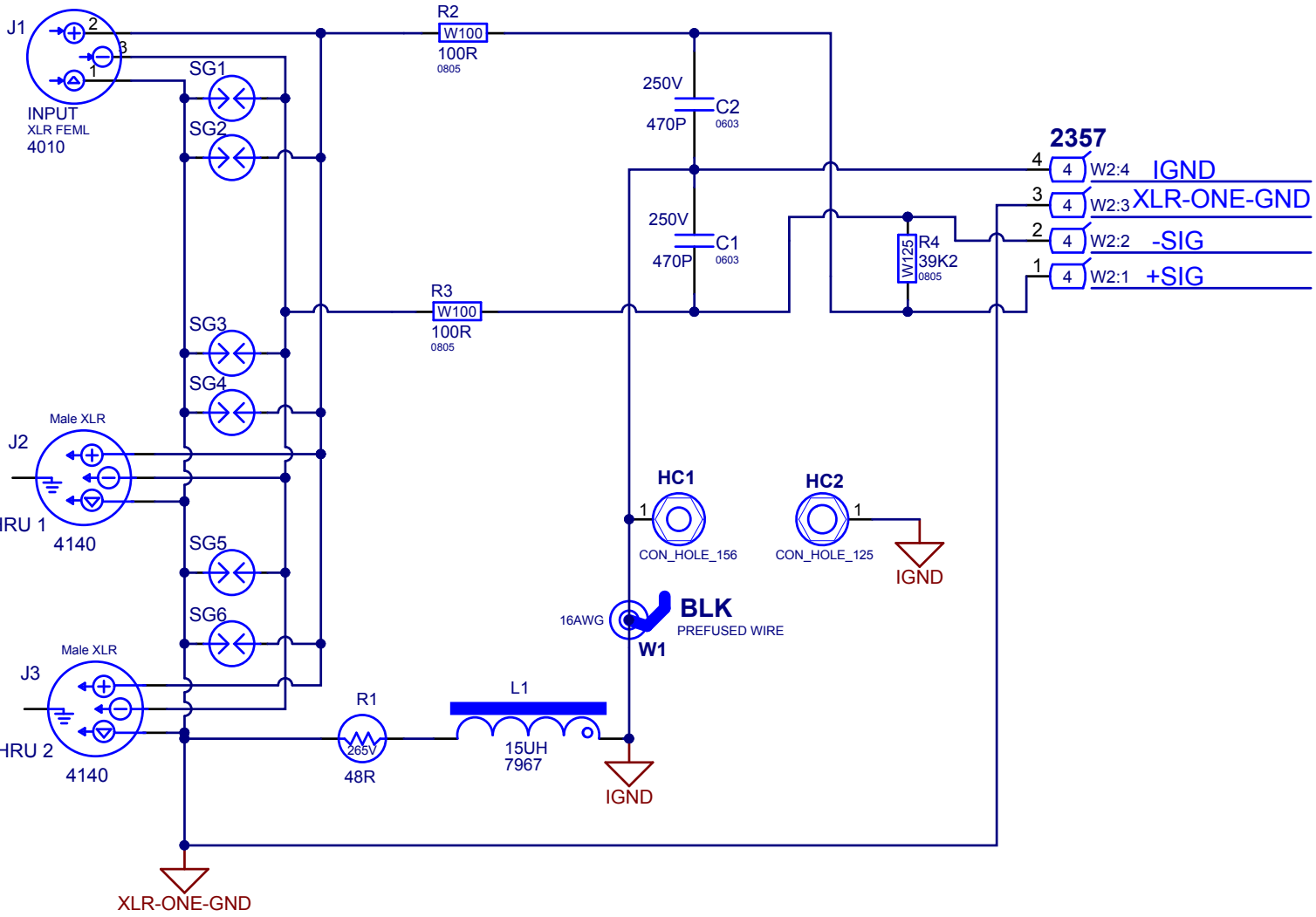

<b>Section:</b> INPUT JACK			
<b>Product(s):</b> SYNERGY			
<b>PCB#:</b> M1813	<b>Rev#:</b> V01	<b>EML Rev#:</b> XX	<b>Sheet</b> 1 <b>Of</b> 2
<b>Modified:</b> 25/10/2018		<b>File:</b> Input.SchDoc	
<b>Temp Rev:</b> V032			

# DESIGN HISTORY AND INFORMATION

## CHANGE HISTORY

#	DATE	VER#	PC#	DESCRIPTION OF CHANGE
1	22-OCT-2018	V01	.	RELEASED FOR PRODUCTION.
2	.	.	.	.
3	.	.	.	.
4	.	.	.	.
5	.	.	.	.
6	.	.	.	.
7	.	.	.	.
8	.	.	.	.
9	.	.	.	.
10	.	.	.	.
11	.	.	.	.
12	.	.	.	.
13	.	.	.	.

  

#	DATE	VER#	PC#	DESCRIPTION OF CHANGE
1	.	.	.	.
2	.	.	.	.
3	.	.	.	.
4	.	.	.	.
5	.	.	.	.
6	.	.	.	.
7	.	.	.	.
8	.	.	.	.
9	.	.	.	.
10	.	.	.	.
11	.	.	.	.
12	.	.	.	.
13	.	.	.	.

#	DATE	VER#	PC#	DESCRIPTION OF CHANGE
1	.	.	.	.
2	.	.	.	.
3	.	.	.	.
4	.	.	.	.
5	.	.	.	.
6	.	.	.	.
7	.	.	.	.
8	.	.	.	.
9	.	.	.	.
10	.	.	.	.
11	.	.	.	.
12	.	.	.	.
13	.	.	.	.

THIS SHEET CONTAINS A CHANGE HISTORY LOG, A LIST OF THE POTS & KNOBS AND A LEADS & PINS REFERENCE SECTION.

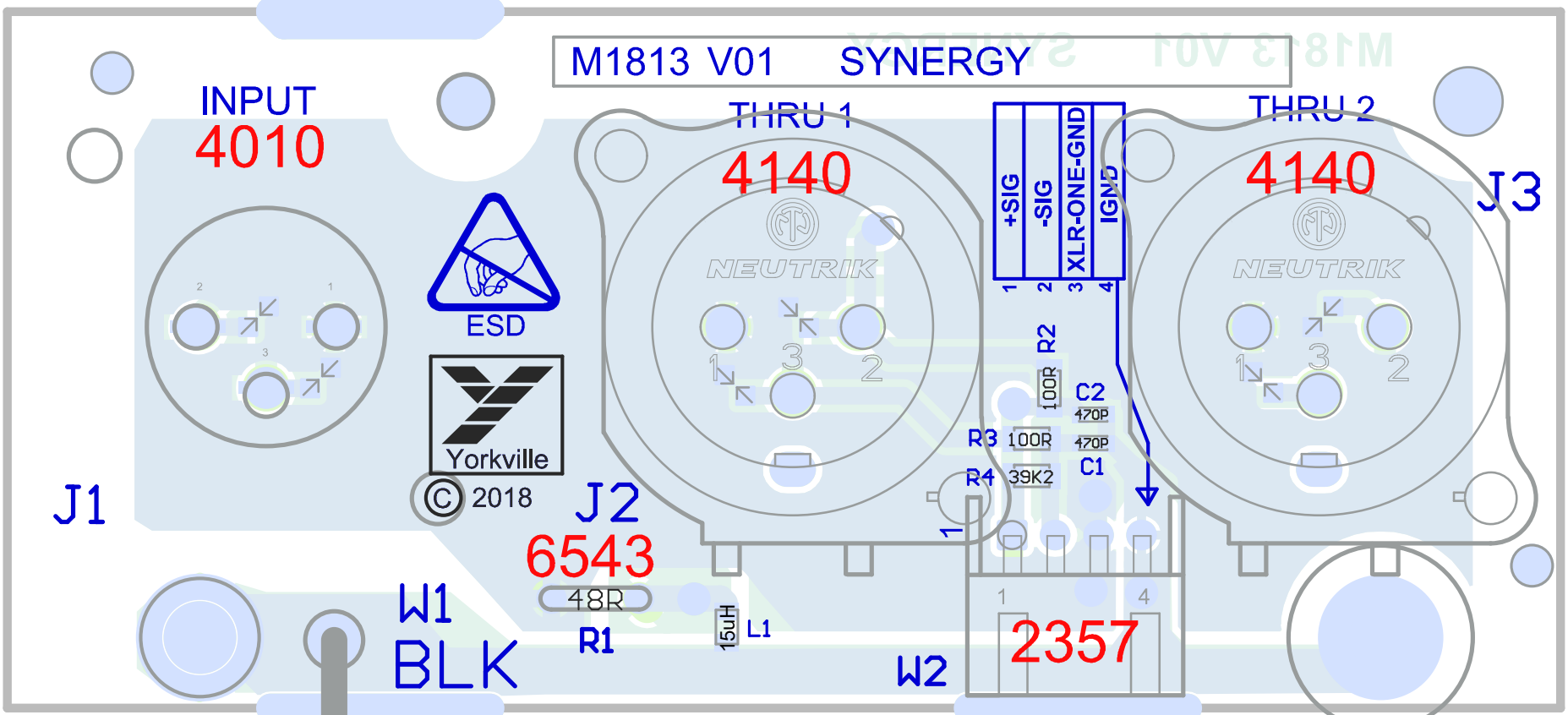

M1813 V01 SYNERGY

INPUT  
4010

THRU 1  
4140

THRU 2  
4140

J3



© 2018

J1

J2

6543

W1  
BLK

48R  
R1

15uH  
L1

W2

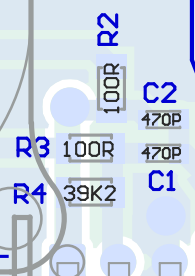
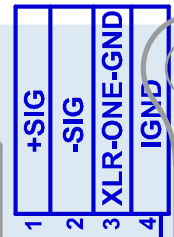

2357

BLACK 5 INCH

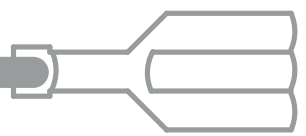

#3489

# PCB ASSEMBLY DOCUMENTATION

## SPECIAL PRODUCTION NOTES

1. PCBSA: R1 #6543 IS HAND INSERTED.

# DESIGN HISTORY AND INFORMATION

## CHANGE HISTORY

#	DATE	VER#	PC#	DESCRIPTION OF CHANGE
1	22-OCT-2018	V01	.	RELEASED FOR PRODUCTION.
2	.	.	.	.
3	.	.	.	.
4	.	.	.	.
5	.	.	.	.
6	.	.	.	.
7	.	.	.	.
8	.	.	.	.
9	.	.	.	.
10	.	.	.	.
11	.	.	.	.
12	.	.	.	.
13	.	.	.	.
#	DATE	VER#	PC#	DESCRIPTION OF CHANGE
1	.	.	.	.
2	.	.	.	.
3	.	.	.	.
4	.	.	.	.
5	.	.	.	.
6	.	.	.	.
7	.	.	.	.
8	.	.	.	.
9	.	.	.	.
10	.	.	.	.
11	.	.	.	.
12	.	.	.	.
13	.	.	.	.
#	DATE	VER#	PC#	DESCRIPTION OF CHANGE
1	.	.	.	.
2	.	.	.	.
3	.	.	.	.
4	.	.	.	.
5	.	.	.	.
6	.	.	.	.
7	.	.	.	.
8	.	.	.	.
9	.	.	.	.
10	.	.	.	.
11	.	.	.	.
12	.	.	.	.
13	.	.	.	.

# POWER SUPPLY SA315S

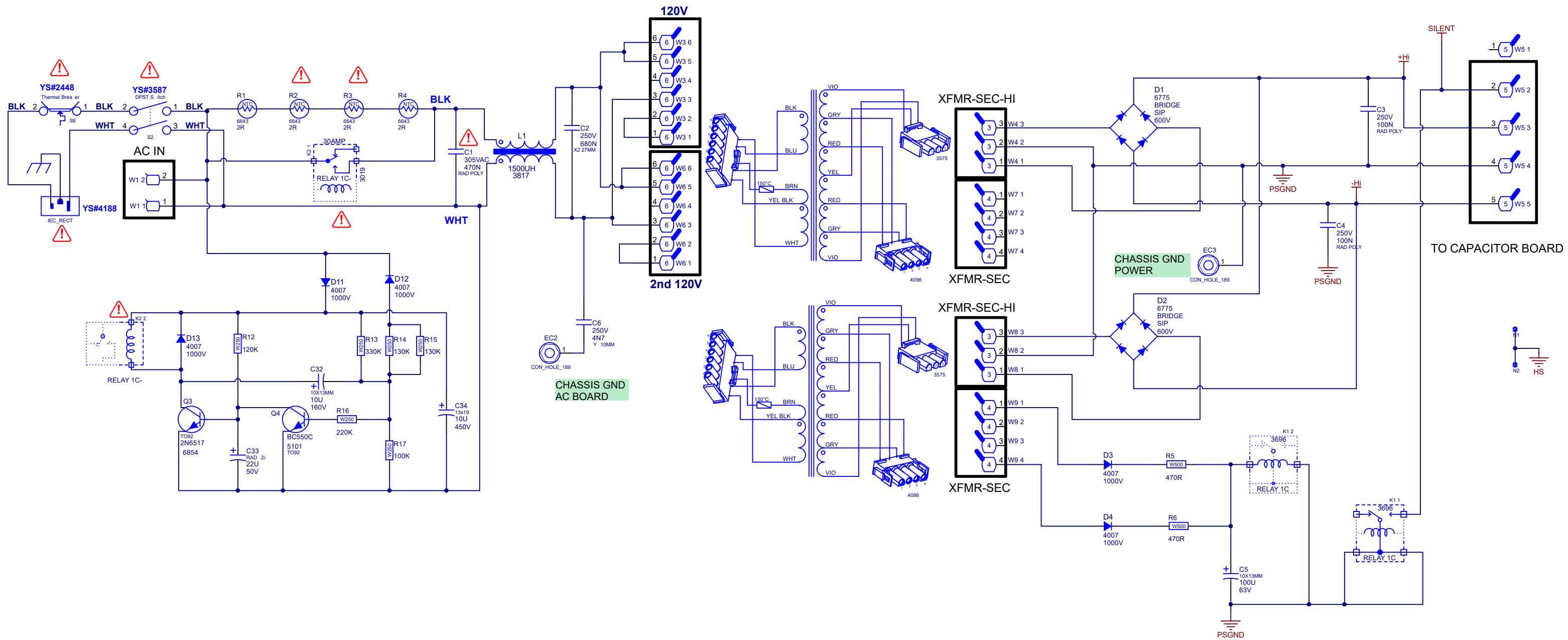

**⚠ CRITICAL SAFETY COMPONENTS**  
 THIS SYMBOL IS PLACED AD ACENT TO  
 SAFETY CRITICAL COMPONENTS.



# DESIGN HISTORY AND INFORMATION

## CHANGE HISTORY

#	DATE	VER#	PC#	DESCRIPTION OF CHANGE
1	12-NOV-2018	V01P1		RELEASED FOR PRODUCTION
2	26-FEB-2019	V02		RELEASED FOR PRODUCTION
3	14-SEP-2023	.	9984	Re lace C1 ith YS 5193 470N
4	.	.	.	.
5	.	.	.	.
6	.	.	.	.
7	.	.	.	.
8	.	.	.	.
9	.	.	.	.
10	.	.	.	.
11	.	.	.	.
12	.	.	.	.
13	.	.	.	.

#	DATE	VER#	PC#	DESCRIPTION OF CHANGE
1	.	.	.	.
2	.	.	.	.
3	.	.	.	.
4	.	.	.	.
5	.	.	.	.
6	.	.	.	.
7	.	.	.	.
8	.	.	.	.
9	.	.	.	.
10	.	.	.	.
11	.	.	.	.
12	.	.	.	.
13	.	.	.	.

## PINOUT DIAGRAMS

Blan Si e 229.870mm 127.000mm(9050 5000)

DRV 03

CLINCH  
ORIGIN

VCD

(9050 5000)

Blan Si e 229.870mm 127.000mm

Into Wa e

Score

Score

Score

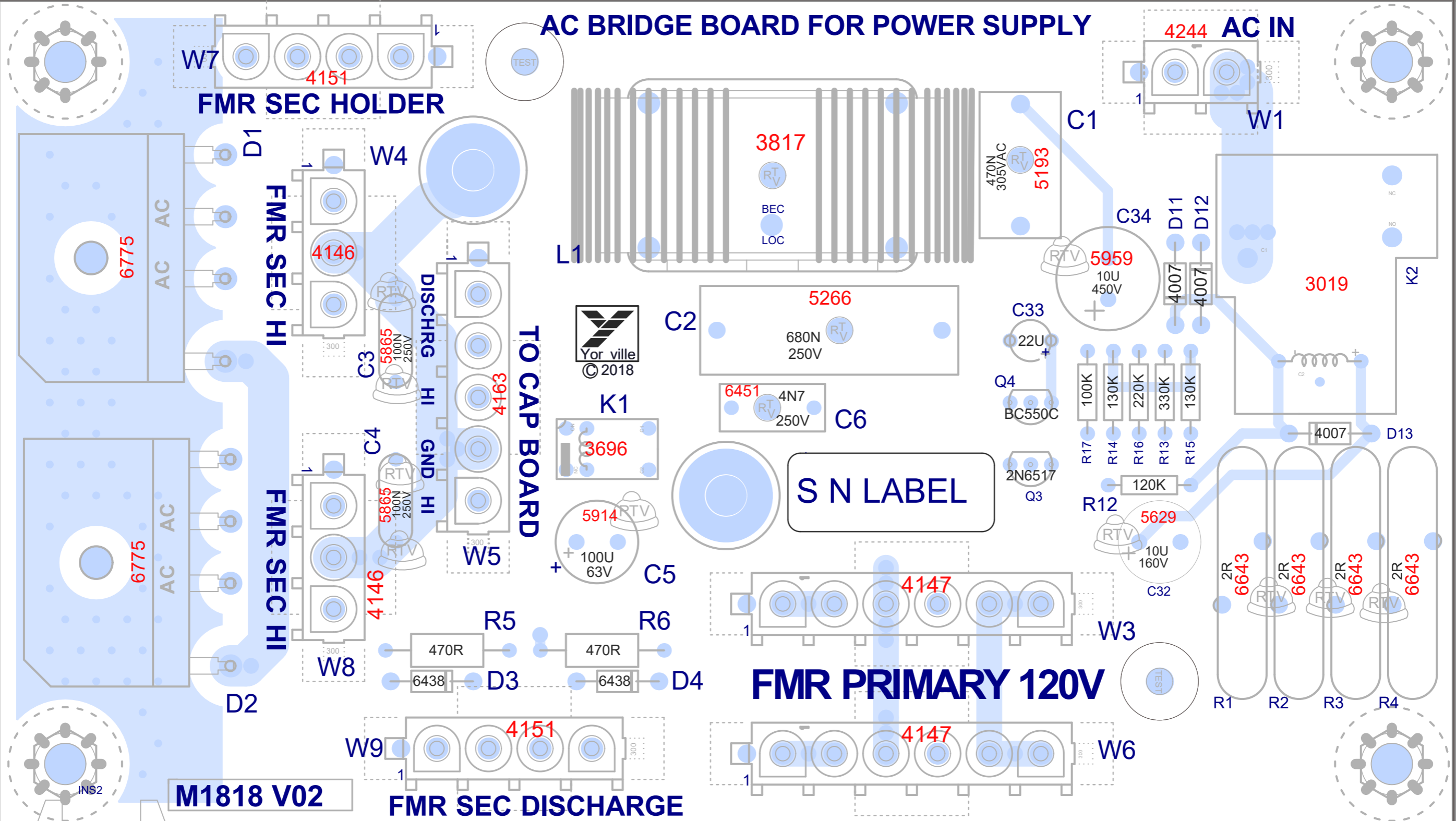

M1818 V02

FMR SEC DISCHARGE

FMR PRIMARY 120V

AC BRIDGE BOARD FOR POWER SUPPLY

FMR SEC HOLDER

FMR SEC HI

FMR SEC HI

S N LABEL

4244 AC IN

M1818 V02 SA115S SA218S SA315S

INSE  
SECON

# PCB ASSEMBLY DOCUMENTATION

1. RTV bet ee tall com o e ts a here i icate
2. Whe a lyi g RTV to R1-R4, it shoul o ly be lace alo g the to s o the varistors.
3. Se arate boar rom a el ith a ro riate tool.

# DESIGN HISTORY AND INFORMATION

## CHANGE HISTORY

#	DATE	VER#	PC#	DESCRIPTION OF CHANGE
1	12-NOV-2018	V01P1		RELEASED FOR PRODUCTION
2	26-FEB-2019	V02		RELEASED FOR PRODUCTION
3	14-SEP-2023	.	9984	Re lace C1 ith YS 5193 470N
4	.	.	.	.
5	.	.	.	.
6	.	.	.	.
7	.	.	.	.
8	.	.	.	.
9	.	.	.	.
10	.	.	.	.
11	.	.	.	.
12	.	.	.	.
13	.	.	.	.

  

#	DATE	VER#	PC#	DESCRIPTION OF CHANGE
1	.	.	.	.
2	.	.	.	.
3	.	.	.	.
4	.	.	.	.
5	.	.	.	.
6	.	.	.	.
7	.	.	.	.
8	.	.	.	.
9	.	.	.	.
10	.	.	.	.
11	.	.	.	.
12	.	.	.	.
13	.	.	.	.

## PINOUT DIAGRAMS



# SUBWOOFER AMP

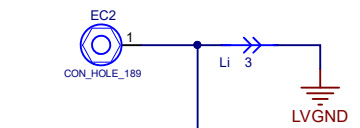

## FROM INPUT PCB

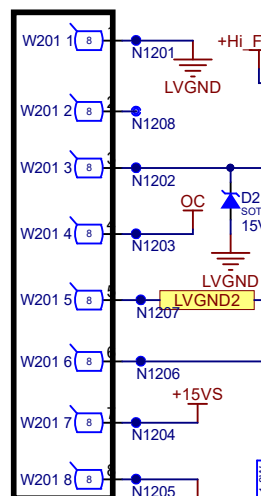

## CAPACITOR BANK

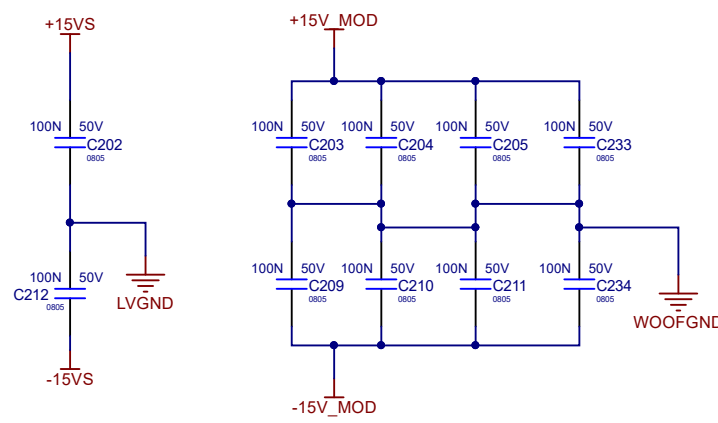
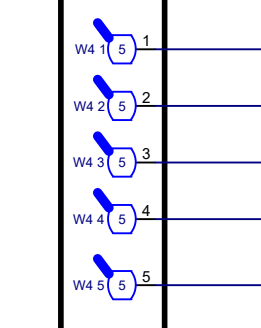

## 15V MOD

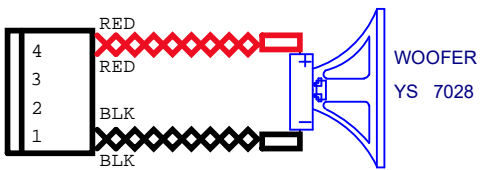
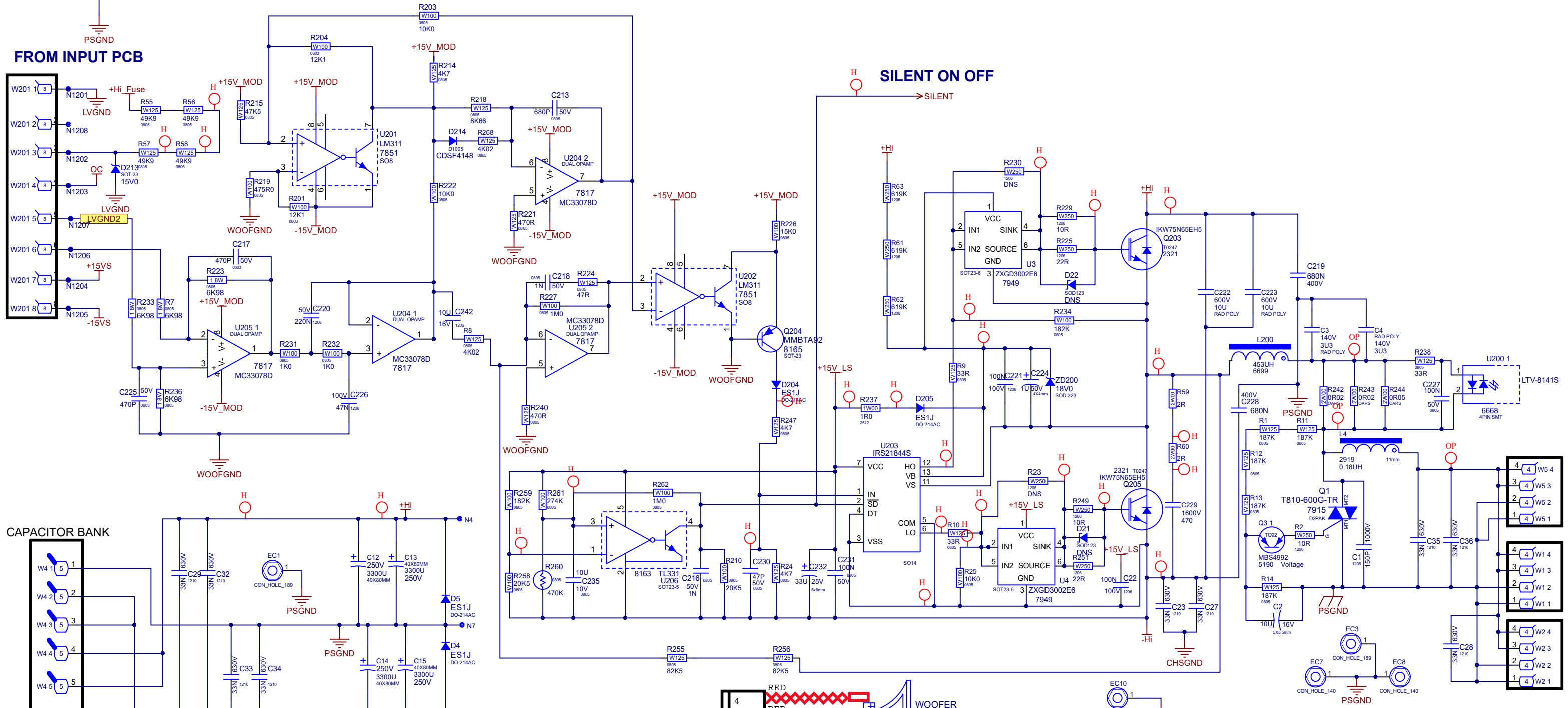
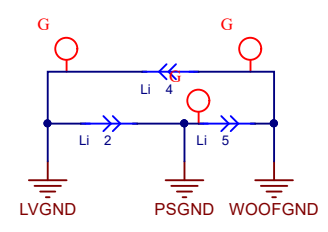
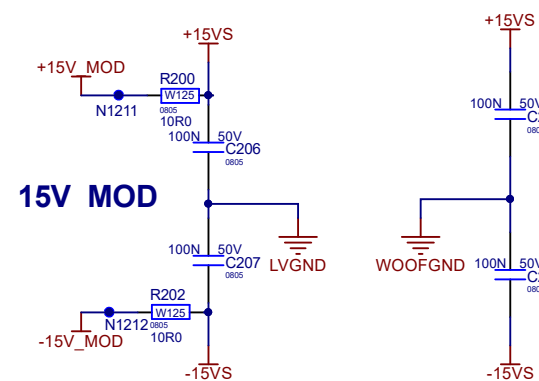

	Section:	Woofer Amp
	Product(s):	SA115S/SA221S
PCB#	Rev#	BOM Rev#
Date Modified:	Filename: A SCHDOC	

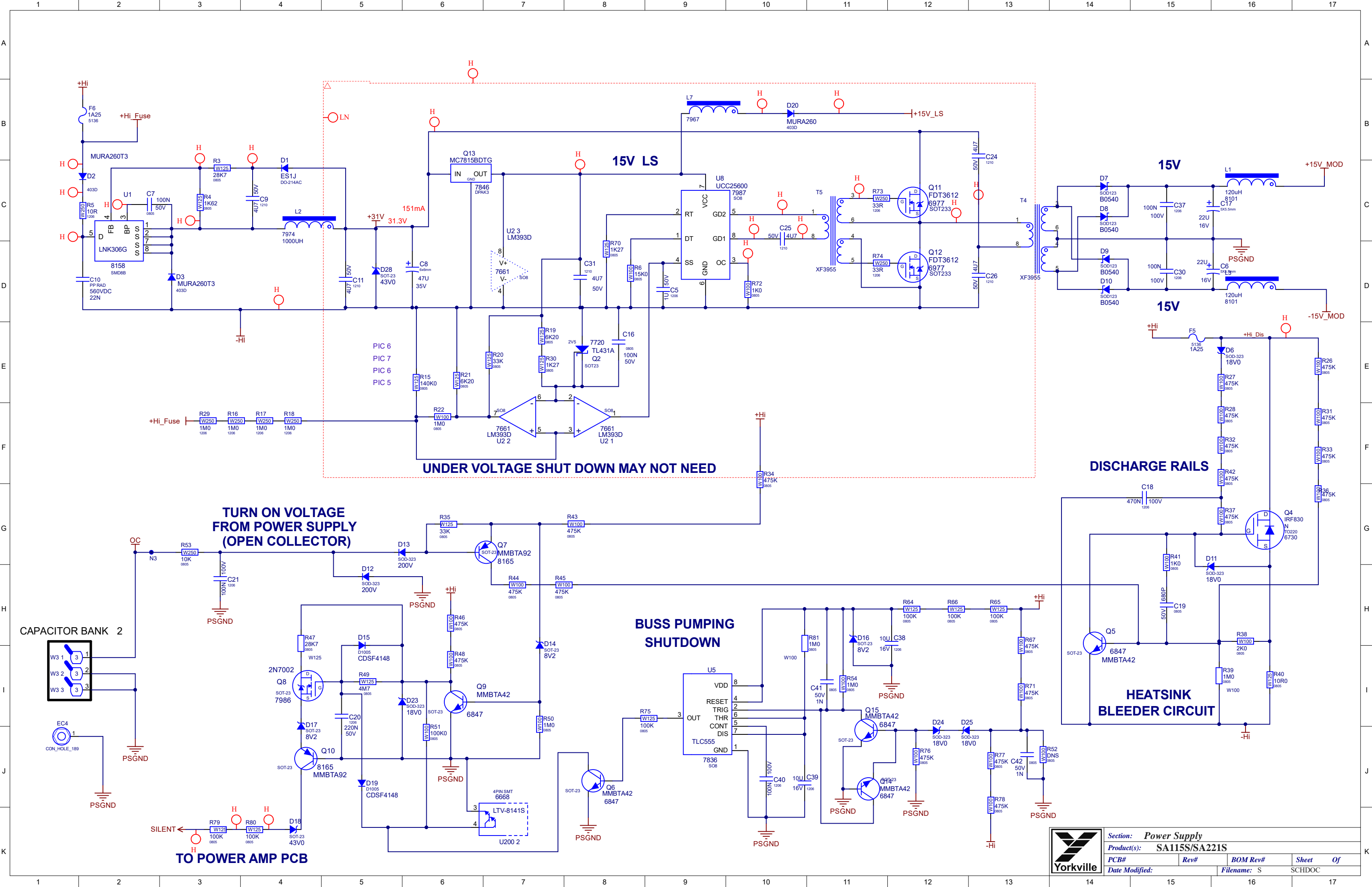

UNDER VOLTAGE SHUT DOWN MAY NOT NEED

TURN ON VOLTAGE FROM POWER SUPPLY (OPEN COLLECTOR)

BUSS PUMPING SHUTDOWN

DISCHARGE RAILS

HEATSINK BLEEDER CIRCUIT

CAPACITOR BANK 2

TO POWER AMP PCB



Section: <b>Power Supply</b>	
Product(s): <b>SA115S/SA221S</b>	
PCB#	Rev#
BOM Rev#	Sheet Of
Date Modified:	Filename: S SCHDOC



Blade - 293.00mmX184.00mm 11535X7244



© 2020

3 OZ. COPPER

SA115S SA221S AMP

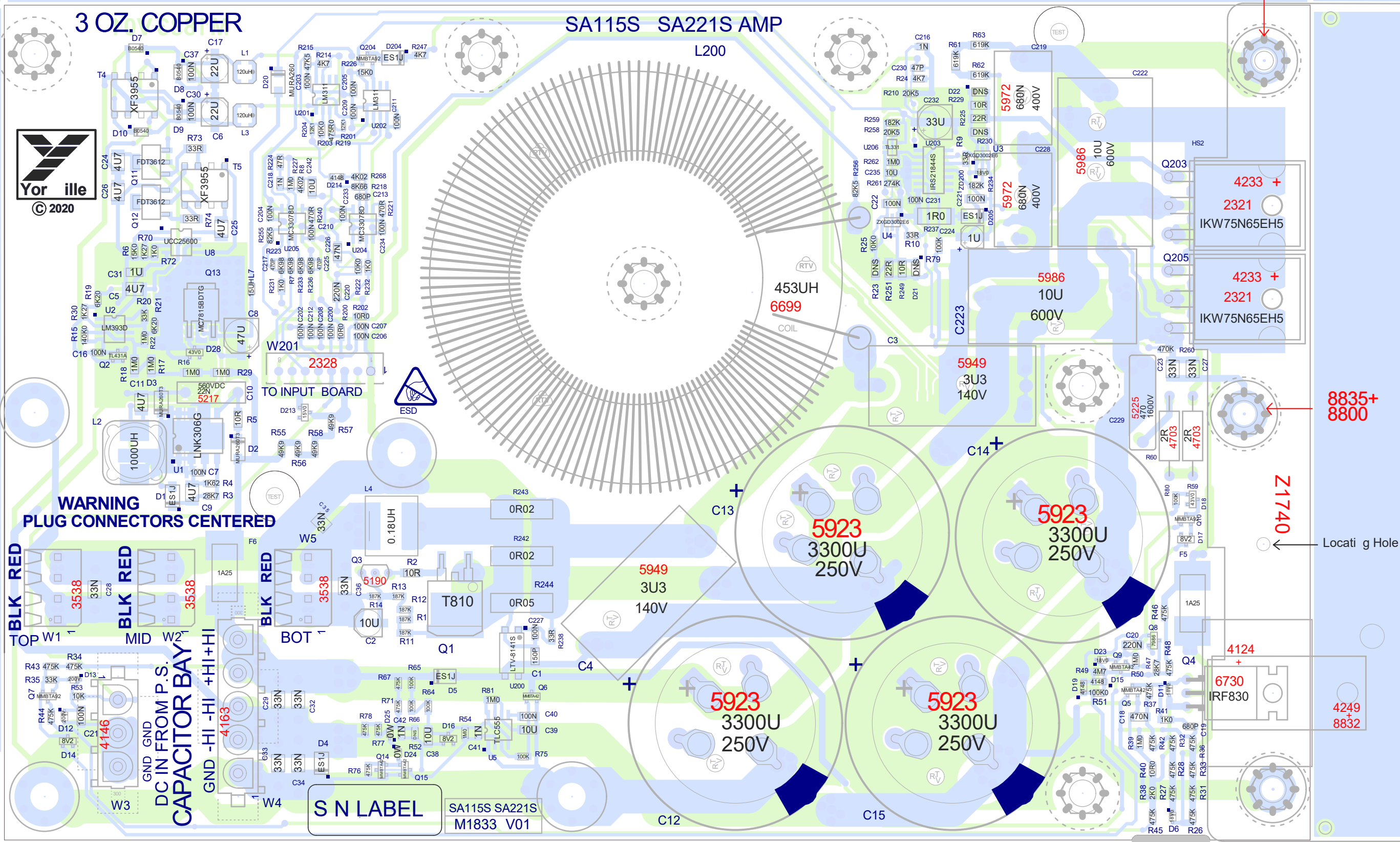

WARNING  
PLUG CONNECTORS CENTERED

DC IN FROM P.S.  
CAPACITOR BAY

S N LABEL

SA115S SA221S  
M1833 V01

M1833 V01

SA115S SA221S

8835+  
8800

4233 +  
2321

4233 +  
2321

8835+  
8800

Z1740

Location Hole

4124 +  
6730

4249  
8832

5923  
3300U  
250V

5923  
3300U  
250V

5923  
3300U  
250V

5923  
3300U  
250V

453UH  
6699  
COIL

5949  
3U3  
140V

5986  
10U  
600V

5225  
470  
1600V

2R  
4703

2R  
4703

C14+

C13

C12

C15

2328

TO INPUT BOARD

5217

560VDC

5217

33N

0.18UH

10U

5190

33N

10R

0R02

0R02

0R05

33R

150P

100N

33R

100K

100K

100K

100K

100K

100K

100K

100K

100K

100K

100K

100K

100K

100K

100K

100K

100K

100K

100K

100K

100K

100K

100K

100K

100K

100K

100K

100K

100K

100K

100K

100K

100K

100K

100K

100K

100K

100K

100K

100K

100K

100K

100K

100K

100K

100K

100K

100K

100K

100K

100K

100K

100K

100K

100K

100K

100K

100K

100K

100K

100K

100K

100K

100K

100K

100K

100K

100K

100K

100K

100K

100K

100K

100K

100K

100K

100K

100K

100K

100K

100K

100K

100K

100K

100K

100K

100K

100K

100K

100K

100K

100K

100K

100K

100K

100K

100K

100K

100K

100K

100K

100K

100K

100K

100K

100K

100K

100K

100K

100K

100K

100K

100K

100K

100K

100K

100K

100K

100K

100K

100K

100K

100K

100K

100K

100K

100K

100K

100K

100K

100K

100K

100K

100K

100K

100K

100K

100K

100K

100K

100K

100K

100K

100K

100K

100K

100K

100K

100K

100K

100K

100K

100K

100K

100K

100K

100K

100K

100K

100K

100K

100K

100K

100K

100K

100K

100K

100K

100K

100K

100K

100K

100K

100K

100K

100K

100K

100K

100K

100K

100K

100K

100K

100K

100K

100K

100K

100K

100K

100K

100K

100K

100K

100K

100K

100K

100K

100K

100K

100K

100K

100K

100K

100K

100K

100K

100K

100K

100K

100K

100K

100K

100K

100K

100K

100K

100K

100K

100K

100K

100K

100K

100K

100K

100K

100K

100K

100K

100K

100K

100K

100K

100K

100K

100K

100K

100K

100K

100K

100K

100K

100K

100K

100K

100K

100K

100K

100K

100K

100K

100K

100K

100K

100K



# PCB ASSEMBLY DOCUMENTATION

## GENERAL ASSEMBLY INSTRUCTIONS

1. Be lea s o ha lace arts i irectio o a a cut short to less tha le gth o a .  
No exce tio s u less a rove by Pro uctio E gi eeri g.
2. A y cli ch arts ith lo ger lea s tha the le gth o the a must be cut shorter either rior to  
ave-sol eri gor a ter ar s i PCB i shi g. No exce tio s u less a rove by Pro uctio E gi eeri g.
3. A ter Wave a ly RTV to all holes i icate a all larger a bet ee tall ca acitors.
4. Be ore tighte i g scre 8832 o xstr s ri g 4249 e sure that it is alig e ith Q4.  
Also sil a 4124 shoul overha g the e ge o the heatsi . See icture belo .

## RTV INSTRUCTIONS:

ADD RTV BETWEEN:  
C12, C13, C14, AND C15 AFTER WAVE  
SOLDER

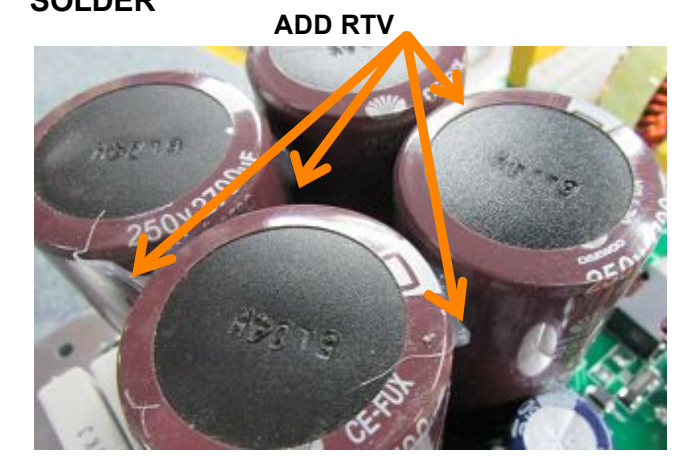

## MOUNTING HARDWARE INSTRUCTIONS FOR HEAT SPREADER 1740:

1. First i stall 8742 scre to alig heats rea er Z1740
2. I stall all evices, sho i ictures belo , o Heat S rea er

### TOP VIEW: MOUNTING HARDWARE FOR Q203 Q205:

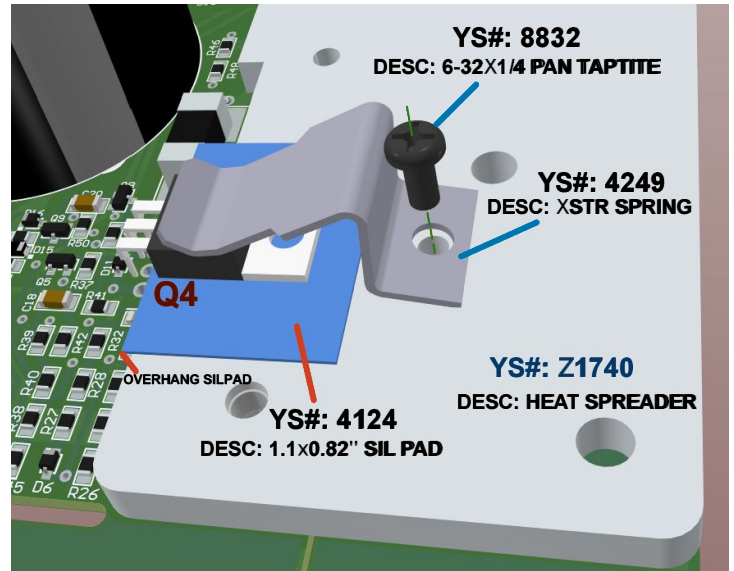
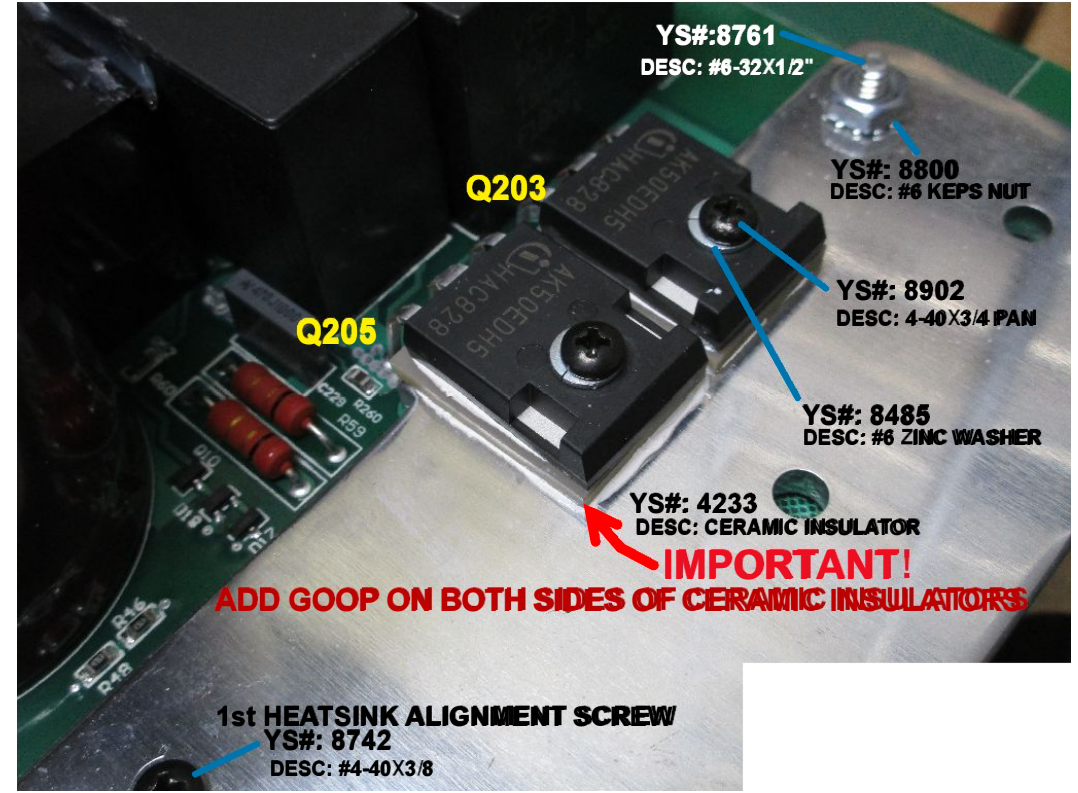

SEE NOTE 4.

### BOTTOM VIEW:

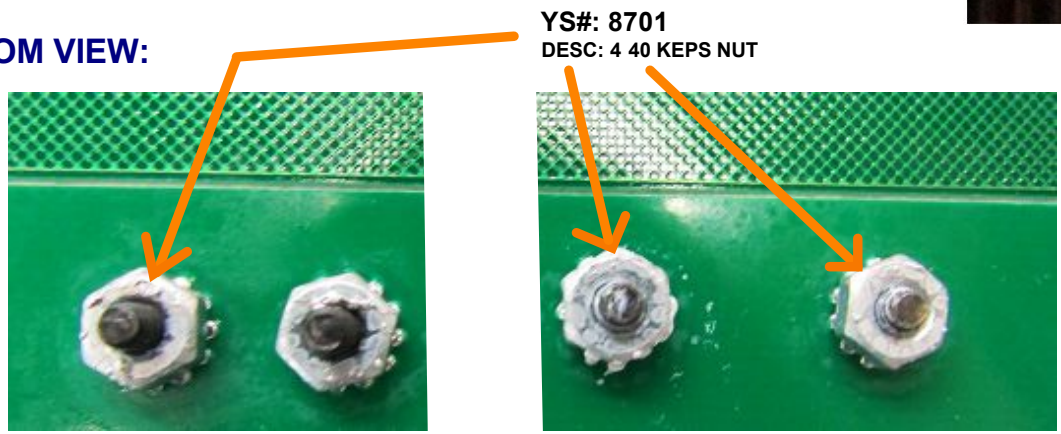

To o Coil L200

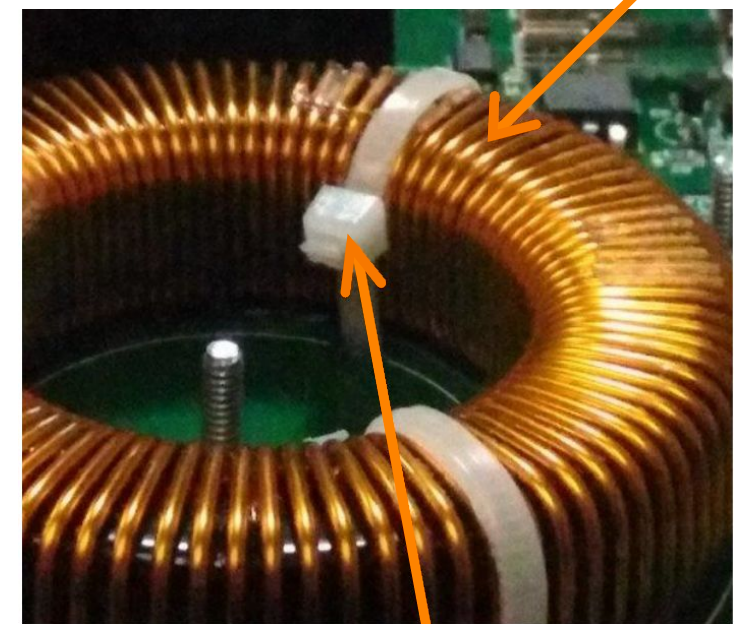

E sure that all aste er ubso tie ra s  
are ell belo the to o the coil.



CAPACITOR BANK 2

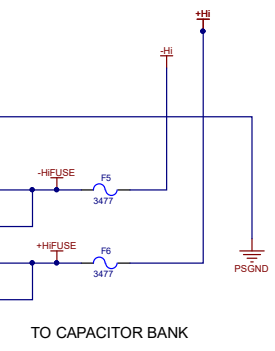
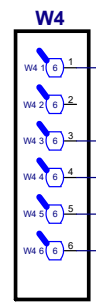
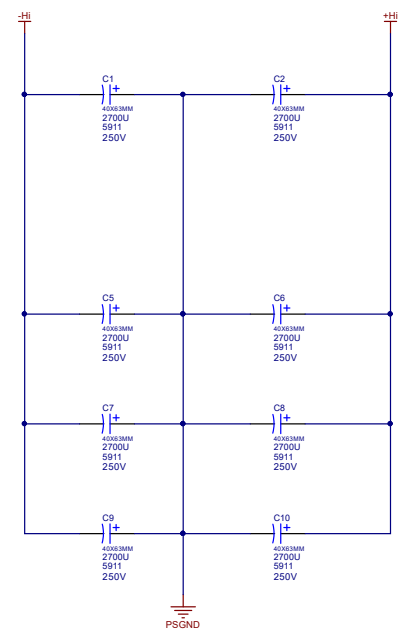
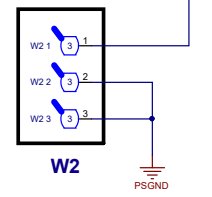

TO CAPACITOR BANK

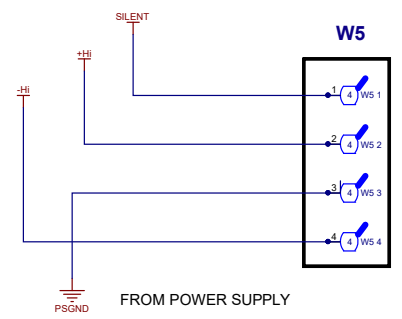

FROM POWER SUPPLY

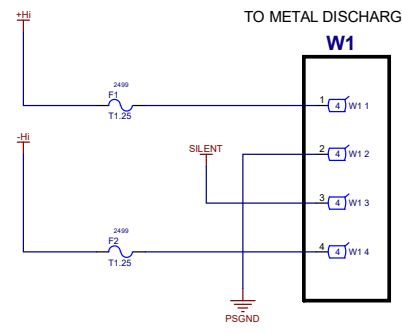

TO METAL DISCHARGE PCB

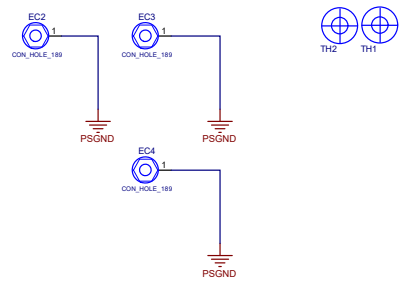

Yorkville Sound Ltd.  
550 Granite Court  
Pickering, ON  
Canada L1W 3Y8  
www.yorkville.com

Product(s): SA115S SA221S	
Description: SA115S SA221S	
PCB#: M1834	Rev: V01
Modified: 2020-11-25	File: M1834.SchDoc
EML Rev#: 02	Sheet 1 Of 4
Temp Rev: V032	



Blan Si e 220.98mm 171.45mm (8700 6750)

### CAUTION DISCHARGE BEFORE SERVICING

USE YS# 8691 ALUM SPACER CHASSIS GND

USE YS# 8691 ALUM SPACER CHASSIS GND

S N LABEL

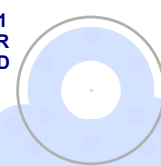
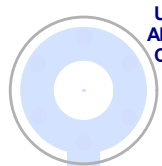
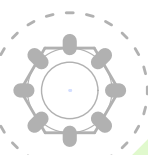

F2 2499

F1 2499

5911  
2700U  
250V

5911  
2700U  
250V

5911  
2700U  
250V

5911  
2700U  
250V

5911  
2700U  
250V

5911  
2700U  
250V

5911  
2700U  
250V

5911  
2700U  
250V

REPLACE WITH RECOMMENDED FUSE

F6 3477

HI FUSE 3477

3477

HI FUSE 3477

F5 3477

SA115S SA221S  
M1834 V01

USE YS# 8691 ALUM SPACER CHASSIS GND

DO NOT DISCONNECT UNTIL BOARD FULLY DISCHARGED

REPLACE FUSE WITH SAME TYPE

TO METAL DISCHARGE PCB

TO POWER AMP

TO POWER AMP

## BREAK OUT

METAL DISCHARGE BOARD

METAL DISCHARGE BOARD

CAUTION DISCHARGE BEFORE SERVICING

### 30 COPPER

## M1834 V01

## SA115S SA221S

USE YS# 8691 ALUM SPACER CHASSIS GND

USE YS# 8691 ALUM SPACER CHASSIS GND

S N LABEL

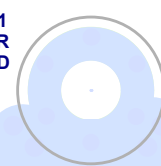
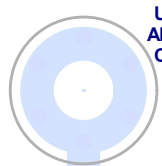
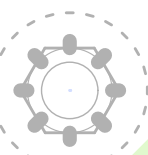

F2 2499

F1 2499

5911  
2700U  
250V

5911  
2700U  
250V

5911  
2700U  
250V

5911  
2700U  
250V

5911  
2700U  
250V

5911  
2700U  
250V

5911  
2700U  
250V

5911  
2700U  
250V

REPLACE WITH RECOMMENDED FUSE

F6 3477

HI FUSE 3477

3477

HI FUSE 3477

F5 3477

SA115S SA221S  
M1834 V01

USE YS# 8691 ALUM SPACER CHASSIS GND

DO NOT DISCONNECT UNTIL BOARD FULLY DISCHARGED

REPLACE FUSE WITH SAME TYPE

TO METAL DISCHARGE PCB

TO POWER AMP

TO POWER AMP

## BREAK OUT

METAL DISCHARGE BOARD

METAL DISCHARGE BOARD

CAUTION DISCHARGE BEFORE SERVICING

### 30 COPPER

## M1834 V01

## SA115S SA221S

# PCB ASSEMBLY DOCUMENTATION

1. When inserting use holders YS 3477, orient them such that the side with the rings match with the rings on the silkscreen as shown in photo 1.
2. RTV all along sides in between all capacitors as shown in photo 2

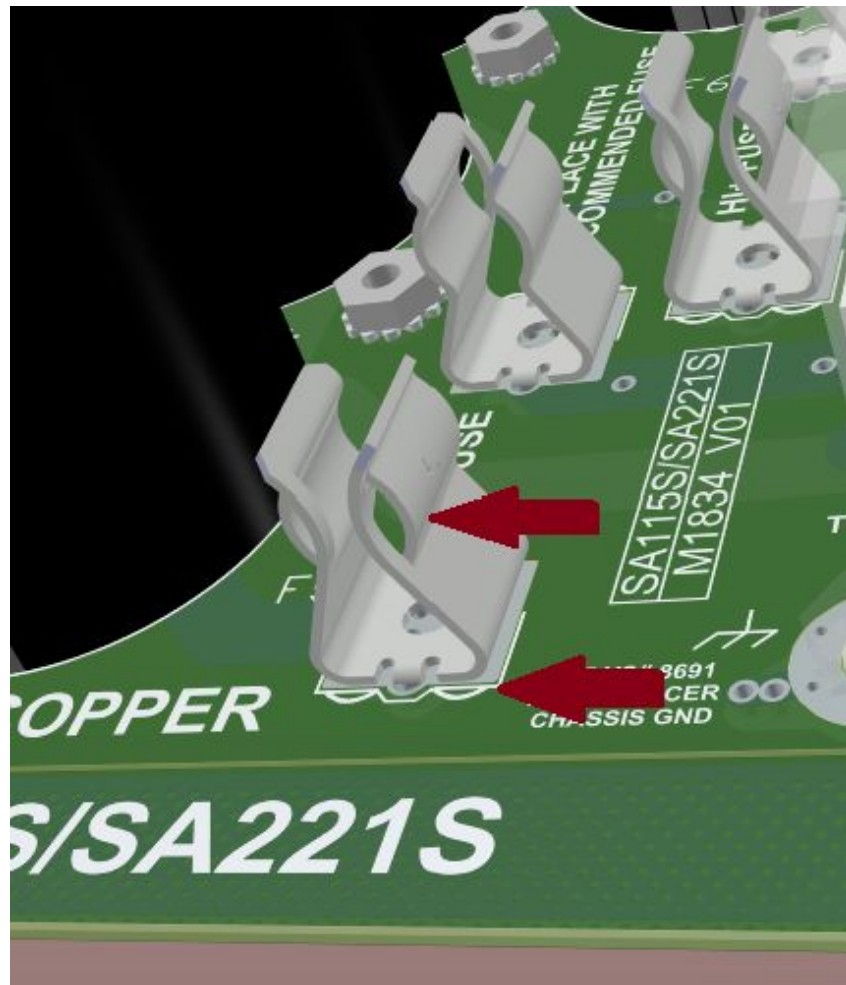

#1



#2



### AC Line Current Sense

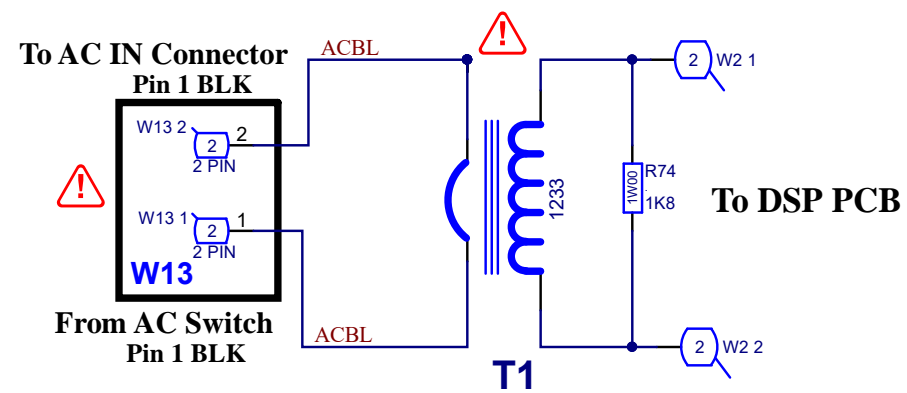

**CRITICAL SAFETY COMPONENTS**  
**THIS SYMBOL IS PLACED AD ACENT TO**  
**SAFETY CRITICAL COMPONENTS.**

### To Cap Boards

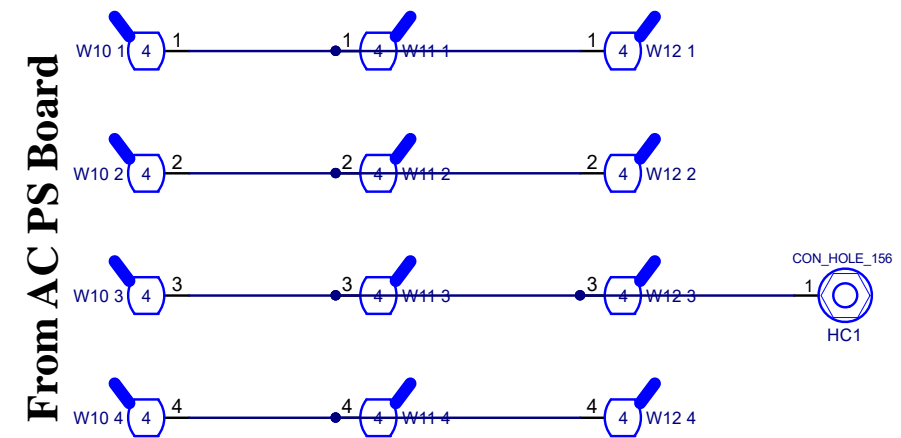

<b>Section: Synergy Current Sense</b>			
<b>Product(s): Synergy</b>			
PCB#: M1837	Rev#: V01	EML Rev#: 01	Sheet 1 Of 4
Modified: 2021-04-15	File: M1837.SchDoc		





Synergy  
M1837V01

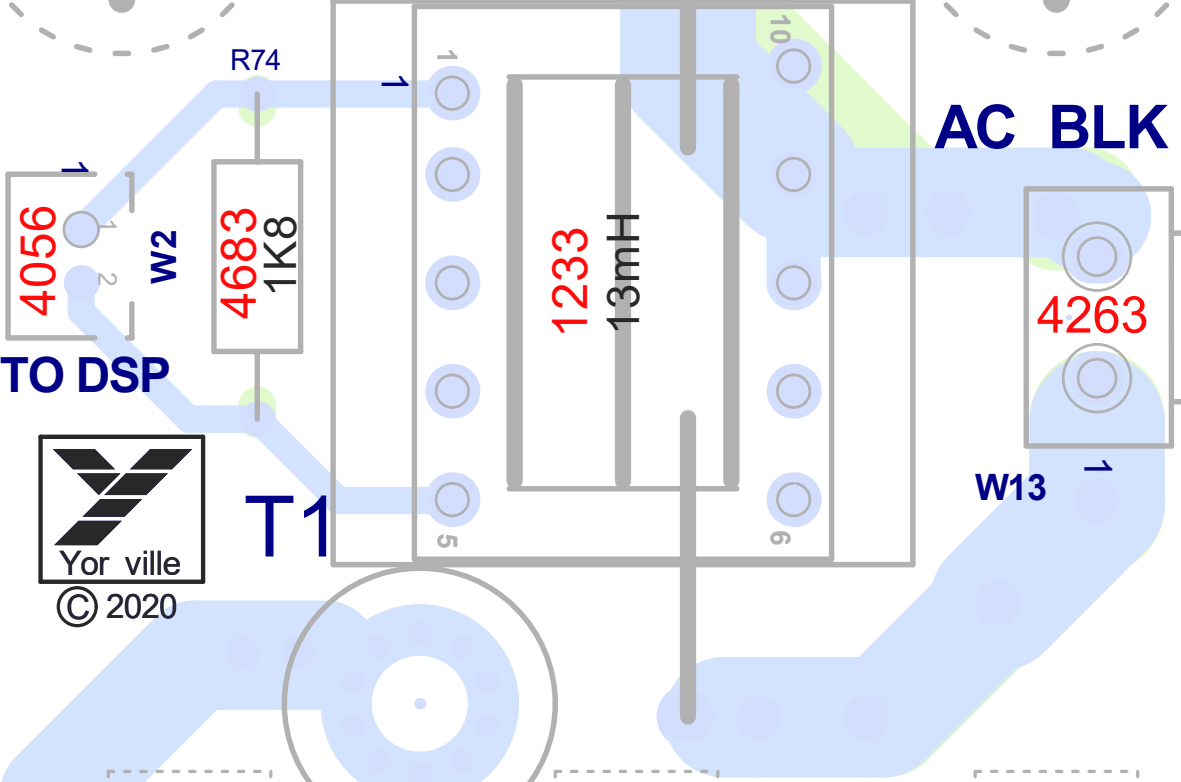

FROM AC PS

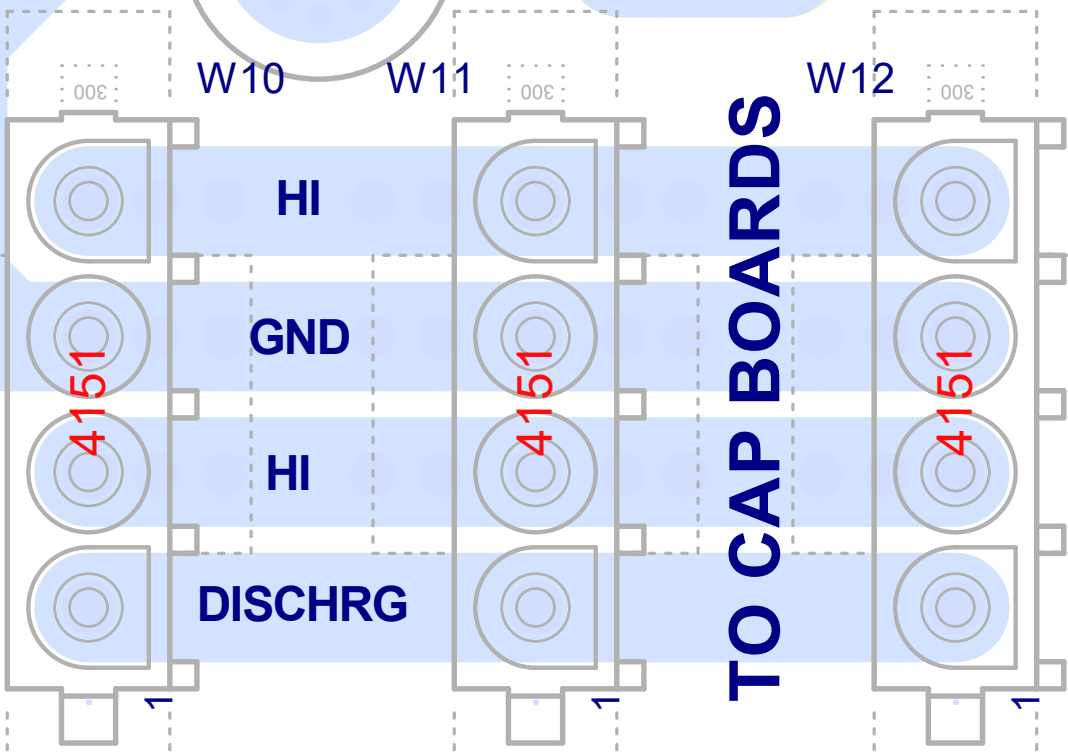

TO CAP BOARDS

AC CURRENT SENSE

S N LABEL

# PCB ASSEMBLY DOCUMENTATION

## Transformer T1 Assembly

1. Be shielded wire as shown in picture 1.
2. Route cable through transformer YS 1233 as shown in pictures 2 and 3.
3. Place transformer on board, and be cable on top as shown in pictures 4 and 5.
4. Leave cable connections to indicator board as shown in picture 5.

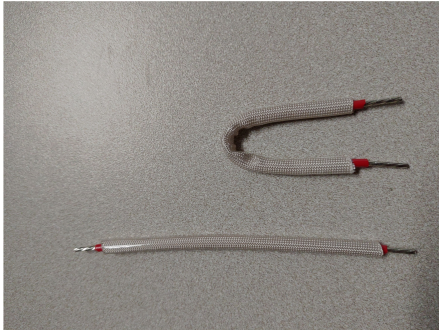

#1

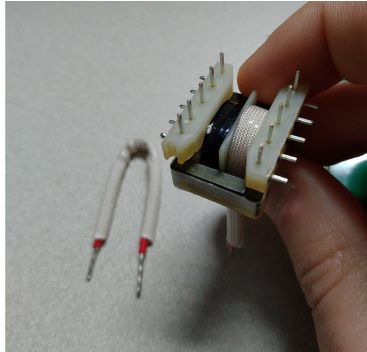

#2

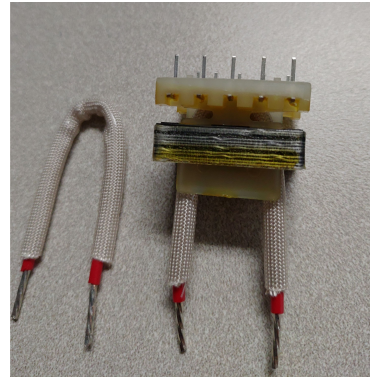

#3

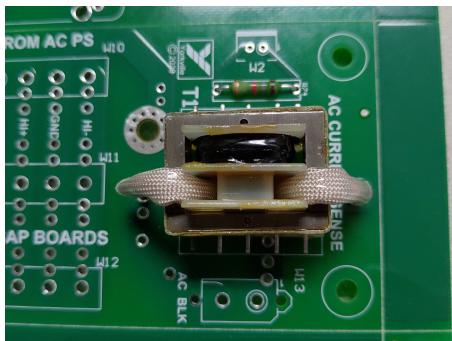

#4

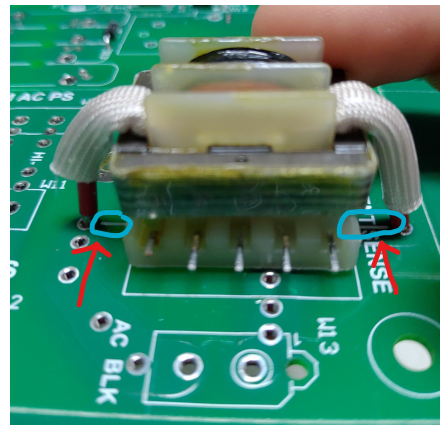

#5

	Section: <b>Assembly Documentation</b>			
	Product(s): <b>Synergy</b>			
	PCB#: M1837	Rev#: V01	EML Rev#: 01	Sheet 2 Of 4
	Modified: 2021-04-15	File: Assembly.SchDoc	Temp Rev: .	



**CHECK RESISTOR VALUES WITH TOM**

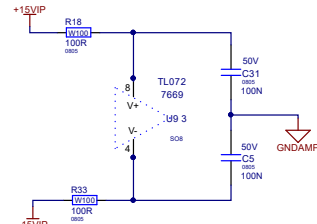
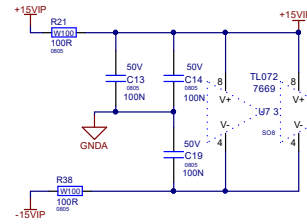

**CODEC B OUTPUT FOR TEST PURPOSE**

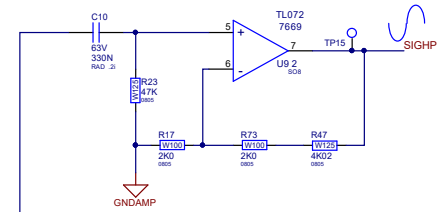

**DSP SHEET**

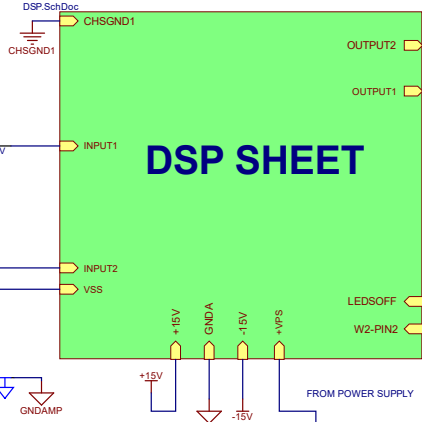

**FROM ACK BOARD**

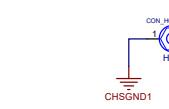
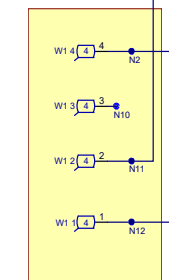

**HP OUTPUT TO SA315S**

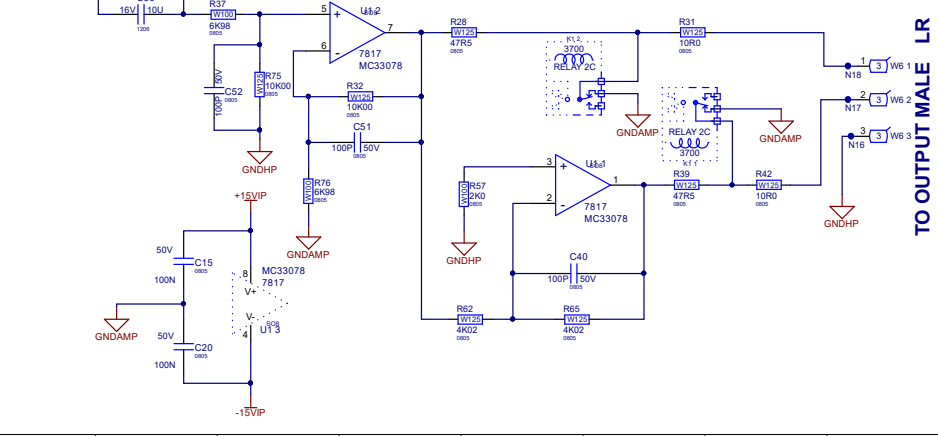

**TO OUTPUT MALE LR 1**

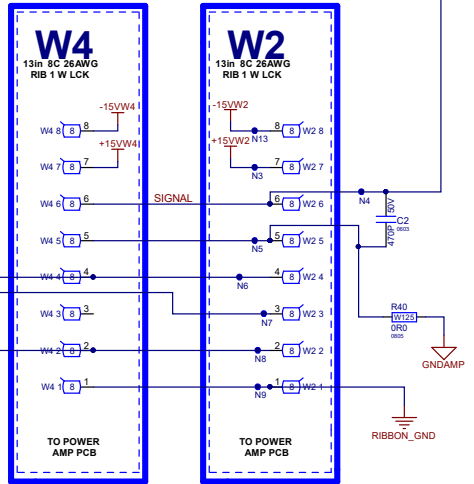
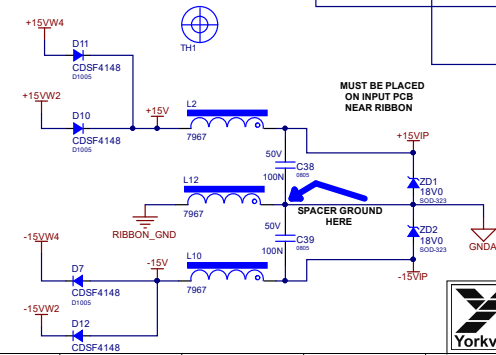
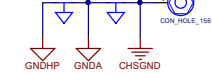

Product(s):		<b>SA115S SA221S</b>		
Description: POWERED SUBWOOFER INPUT PCB				
PCB#: M1950	Rev: V01	EML Rev: V01	Sheet 1 of 3	
Mod/Rev: 2021-03-03	File: INPUT.SchDoc			Temp Rev: V031

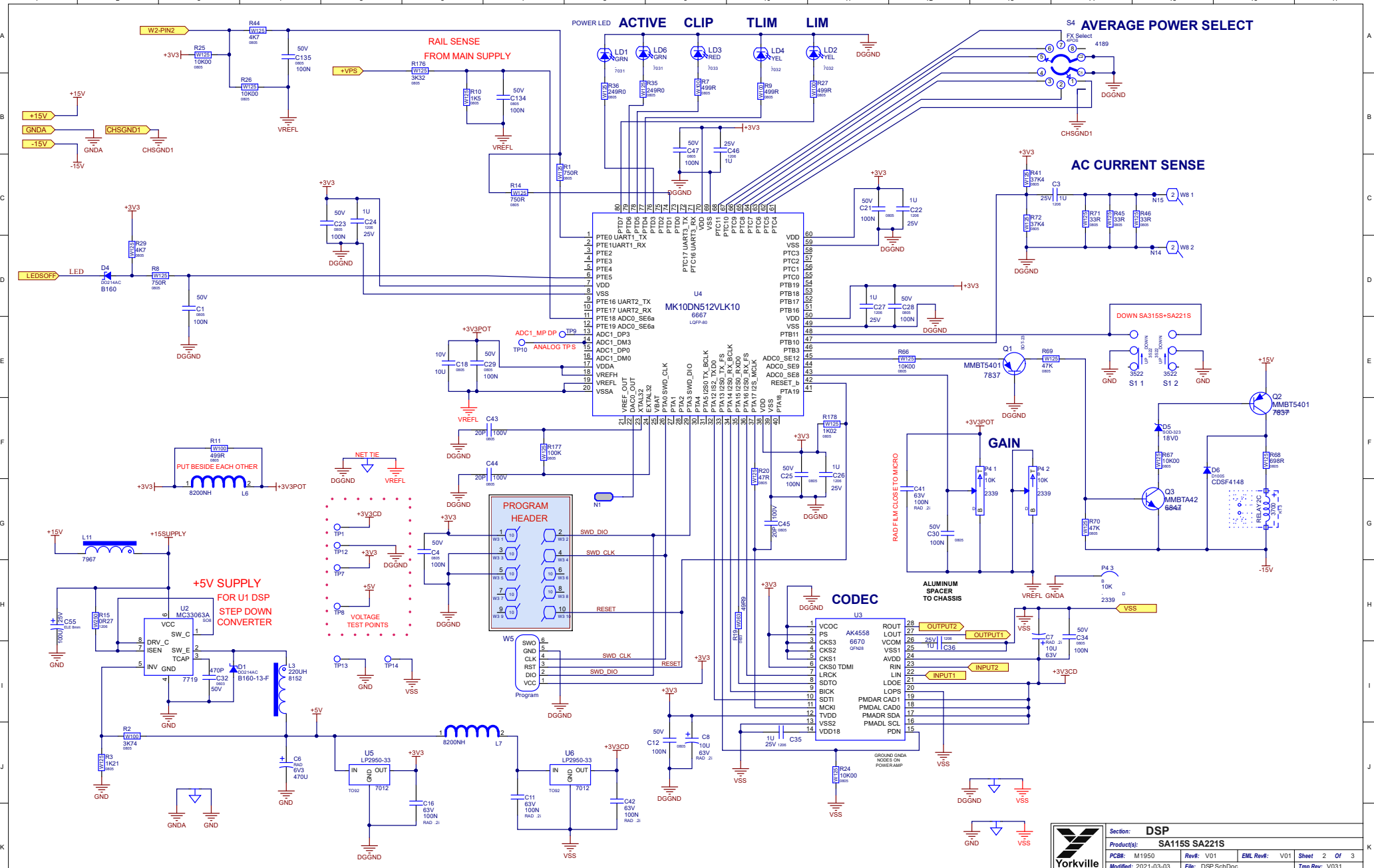

	Section:	DSP					
	Product(s):	SA115S SA221S					
	PCBR:	M1950	Rev:	V01			
	Modifed:	2021-03-03	File:	DSP-SchDoc			
		EML Rev:	V01	Sheet	2	Of	3
				Temp Rev:	V031		



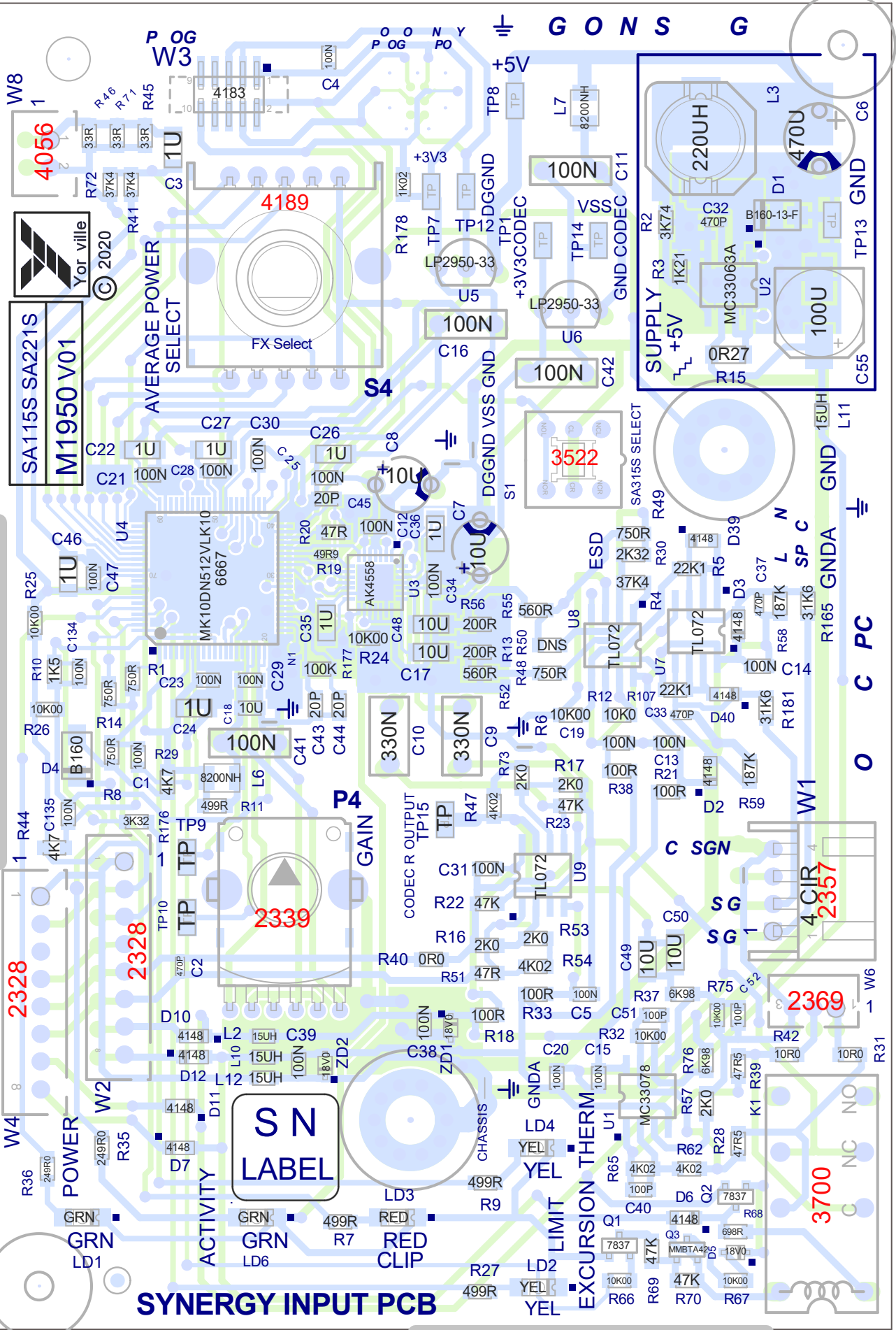

W8  
1  
4056

SA1155 SA221S  
M1950 V01

2328

POWER  
ACTIVITY

POG W3

AVERAGE POWER  
SELECT

FX Select

2339

SN LABEL

4189

S4

P4 GAIN

2369

RED CLIP

POG W3

4183

100N

100N

100N

100N

100N

100N

100N

100N

100N

100N

100N

100N

POG W3

100N

100N

100N

100N

100N

100N

100N

100N

100N

100N

100N

100N

100N

100N

100N

POG W3

100N

100N

100N

100N

100N

100N

100N

100N

100N

100N

100N

100N

100N

100N

100N

POG W3

100N

100N

100N

100N

100N

100N

100N

100N

100N

100N

100N

100N

100N

100N

100N

POG W3

100N

100N

100N

100N

100N

100N

100N

100N

100N

100N

100N

100N

100N

100N

100N

# SYNERGY INPUT PCB



# PCB ASSEMBLY DOCUMENTATION

## SPECIAL PRODUCTION NOTES

- 1.AFTER WAVE USE PIZZA CUTTER TO SEPARATE THE BOARDS.
- 2.IF REQUIRED USE A JIG FOR INPUT JACK POT SWITCH ALIGNMENT.

## PCB HARDWARE

SC WS N OL S | N S | S N O S | SC LL N O S

THIS SHEET CONTAINS SPECIAL PRODUCTION NOTES AND A LIST OF PCB HARDWARE PARTS REQUIRED FOR THE BUILD.



Section: <b>Assembly Documentation</b>			
Product(s): <b>SA115S SA221S</b>			
PCB#: M1950	Rev#: V01	EML Rev#: V01	Sheet 2 Of 3
Modified: 2021-03-03	File: Assembly.SchDoc	Tmp Rev: V031	

# DESIGN HISTORY AND INFORMATION

## CHANGE HISTORY

#	DATE	VER#	PC#	DESCRIPTION OF CHANGE
1	26-NOV-2020	V01	.	RELEASE FOR PRODUCTION
2	.	.	.	.
3	.	.	.	.
4	.	.	.	.
5	.	.	.	.
6	.	.	.	.
7	.	.	.	.
8	.	.	.	.
9	.	.	.	.
10	.	.	.	.
11	.	.	.	.
12	.	.	.	.
13	.	.	.	.
#	DATE	VER#	PC#	DESCRIPTION OF CHANGE
1	.	.	.	.
2	.	.	.	.
3	.	.	.	.
4	.	.	.	.
5	.	.	.	.
6	.	.	.	.
7	.	.	.	.
8	.	.	.	.
9	.	.	.	.
10	.	.	.	.
11	.	.	.	.
12	.	.	.	.
13	.	.	.	.
#	DATE	VER#	PC#	DESCRIPTION OF CHANGE
1	.	.	.	.
2	.	.	.	.
3	.	.	.	.
4	.	.	.	.
5	.	.	.	.
6	.	.	.	.
7	.	.	.	.
8	.	.	.	.
9	.	.	.	.
10	.	.	.	.
11	.	.	.	.
12	.	.	.	.
13	.	.	.	.

## POTENTIOMETERS AND KNOBS

POTENTIOMETERS SWITCHES AND KNOBS				
REF	FUNCTION	POT SW YS#	STYLE	KNOB#
S1	MODE SELECT	4202	ROT	8653C
S4	HF ROLL OFF	4202	ROT	8653C
P4	GAIN	2339	P34	8653C
.	.	.	.	.
.	.	.	.	.
.	.	.	.	.
.	.	.	.	.
.	.	.	.	.
.	.	.	.	.
.	.	.	.	.
.	.	.	.	.
.	.	.	.	.
.	.	.	.	.
.	.	.	.	.
.	.	.	.	.
.	.	.	.	.

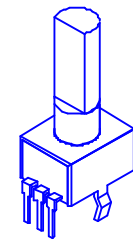

STYLE P32

## PINOUT DIAGRAMS

THIS SHEET CONTAINS A CHANGE HISTORY LOG, A LIST OF THE POTS & KNOBS AND A LEADS & PINS REFERENCE SECTION.



Section: <b>Design Information And History</b>			
Product(s): <b>SA115S SA221S</b>			
PCB#: M1950	Rev#: V01	EML Rev#: V01	Sheet 3 Of 3
Modified: 2021-03-03	File: History.SchDoc	Tmp Rev: V031	



# SYNERGY

ACTIVE SUBWOOFER

## SA115S

### 1. Power Switch and Indicator

The green power LED illuminates when the power switch is turned to the On position and AC voltage is supplied. When the power is removed or the power switched is moved to the off position the green power indicator will blink while the power supply is discharging. The processing circuitry will not reboot unless the power supply is fully discharged before being turned back on. It is not necessary to reboot however. Turning the power back on before the power supply is discharged will simply resume normal operation.

### 2. PowerCON TRUE AC Loop Thru

As a standard, the AC inlet on the SA115S accepts locking PowerCON TRUE power cords. There is also an AC outlet that can be used to loop power through to other cabinets in your array using a male to female PowerCON TRUE looping power cord. Check with your local Yorkville dealer for availability of these accessory cords.

*IMPORTANT: DO NOT EXCEED THE CURRENT RATING OF THE POWER and ACCESSORY CORDS. PLEASE READ THE SECTION OF THIS MANUAL CALLED "CASCADE INSTALLATION."*

### 3. Input Jack

This female-XLR accepts line level XLR microphone cables. For best noise reduction use balanced sources.

### 4. Dual Link Outputs

These XLR male connectors can be used with a standard XLR cable to daisy-chain up to 20 SA115S or SA315 cabinets without signal degradation. Simply loop from one cabinet's Link jack to the next cabinets Input jack. In many cases this limit of 20 cabinets can be exceeded, consult Yorkville Sound for more details.

### 5. SA115S Level Control

This control adjusts the volume level of the SA115S relative to the input signal level. Mixers and other audio sources connected to the SA115S tend to have different output voltages, which mean the level control on the SA115S is used to fine tune the cabinet's volume relative to the mixer settings. It is perfectly acceptable to set the SA115S Level above or below the center 0 dB setting.

### 6. Clip, X-Max, VC-Therm, Activity Indicators

The Clip and Limit LED indicators illuminate to guide the user to proper operating levels.

Illumination either of the yellow Limit LEDs indicates that a level has been reached where the SA115S limiters are reducing the signal internally to prevent damage or distortion. It also indicates that further increases in input level or increasing the SA115S Level control position will not appreciably increase acoustic output.

The red Clip LED indicates that the input level is excessive and further increases in level will cause severe distortion. The input signal should be reduced at the source until Clip activity ceases. The clip indicator comes on at 12 Vrms, 16 volts peak. The input clips at 17 Vrms, 24 volts peak.

*The activity Indicator comes on at 5 mVrms or -45 dBV.*

### 7. Line Current Limit Control

The Line Current Limit control allows the power to be reduced to allow operation on limited power availability. Full power transients will be allowed through but if the average power is excessive then the power will be limited. This control works by advancing the limiter that limits the voice coil temperature and by monitoring the current draw. In the 5 amp position the average power is limited only by the voice coil temperature. In the 4 amp position with most music, the limiter will be only active occasionally depending on the music content. In the 3 amp position certain types of music will not be limited, primarily music without deep bass or where the bass is unprocessed. The 2 amp position will significantly reduce the output when the music content has continuous bass content below 45 Hz. The green power on indicator will dim to indicate when the line current limiter is active. A small amount of dimming indicates that the advanced thermal limiter is active while significant dimming indicates that the line current monitoring system has detected excessive line current. Low line voltage typically due to long power supply cables may cause excessive line current, the line current monitoring system will prevent this from tripping the power source circuit breakers.

To get the full Owner's Manual please visit our website at

<http://www.yorkville.com/manuals/> or, if you need a printed version call 905-837-8777

**REAL Gear.  
REAL People.**



Canada  
Voice: (905) 837-8481  
Fax: (905) 837-8746

U.S.A.  
Voice: (716) 297-2920  
Fax: (716) 297-3689

[www.yorkville.com](http://www.yorkville.com)

Yorkville Sound  
550 Granite Court  
Pickering, Ontario  
L1W-3Y8 CANADA

Yorkville Sound Inc.  
4625 Witmer Industrial Estate  
Niagara Falls, New York  
14305 USA

Printed In CANADA

QuickStart-SA115S-00-1v0 • YS#QSTART-SA115S • May 11, 2021



# SYNERGY

ACTIVE SUBWOOFER

## SA115S

### 1. Interrupteur et Indicateur d'Alimentation

Le voyant d'alimentation vert s'allume lorsque l'interrupteur d'alimentation est réglé sur la position ON et que la tension CA est appliquée. Lorsque l'alimentation est coupée ou que l'interrupteur d'alimentation est placé en position OFF, le voyant vert d'alimentation clignote pendant que l'alimentation se décharge. Le circuit de traitement ne redémarrera pas si l'alimentation n'est pas complètement déchargée avant d'être remise sous tension. Il n'est cependant pas nécessaire de redémarrer. Si vous remettez l'appareil sous tension avant que l'alimentation ne soit déchargée, le fonctionnement normal reprendra simplement.

### 2. Boucle CA PowerCON TRUE

En standard, l'entrée CA du SA115S est compatible avec les cordons d'alimentation PowerCON TRUE à verrouillage. Il y a également une prise CA qui peut être utilisée pour alimenter en boucle d'autres enceintes de votre réseau en utilisant un cordon d'alimentation PowerCON TRUE mâle à femelle. Vérifiez auprès de votre revendeur Yorkville local pour vérifier la disponibilité de ces cordons accessoires.

**IMPORTANT: NE PAS DÉPASSER LE COURANT MAXIMAL DES CORDONS D'ALIMENTATION ET D'ACCESSOIRES. VEUILLEZ LIRE LA SECTION DU MANUEL DU PROPRIÉTAIRE APPELÉ "INSTALLATION EN CASCADE."**

### 3. Prise d'Entrée

Cette prise femelle-XLR est compatible avec les câbles de microphone XLR de niveau ligne. Pour une meilleure réduction du bruit, utilisez des sources équilibrées.

### 4. Sorties Dual Link

Ces connecteurs mâles XLR peuvent être utilisés avec un câble XLR standard pour relier en chaîne jusqu'à 20 enceintes SA115S ou SA315 sans dégradation du signal. Il suffit de faire une boucle entre la prise Link d'une enceinte et la prise Input de l'enceinte suivante. Dans de nombreux cas, cette limite de 20 enceintes peut être dépassée, consultez Yorkville Sound pour plus de détails.

### 5. Commande de Niveau SA115S

Cette commande permet de régler le niveau de volume du SA115S par rapport au niveau du signal d'entrée. Les tables de mixage et autres sources audio connectées au SA115S ont tendance à avoir des tensions de sortie différentes, ce qui signifie que la commande de niveau sur le SA115S est utilisé pour affiner le volume de l'enceinte par rapport aux réglages de la table de mixage. Il est parfaitement acceptable de régler le niveau du SA115S au-dessus ou au-dessous du réglage central de 0 dB.

### 6. Indicateurs d'Activité Clip, X-Max, VC-Therm,

Les indicateurs DEL Clip et Limit s'allument pour guider l'utilisateur vers les niveaux de fonctionnement appropriés.

L'illumination de l'une ou l'autre des DEL jaunes de limite indique qu'un niveau a été atteint où les limiteurs du SA115S réduisent le signal de façon interne pour éviter tout dommage ou distorsion. Il indique également que d'autres augmentations du niveau d'entrée ou de la position de la commande de niveau du SA115S n'augmenteront pas sensiblement la sortie acoustique.

La DEL Clip rouge indique que le niveau d'entrée est excessif et que toute augmentation supplémentaire du niveau entraînera une distorsion grave. Le signal d'entrée doit être réduit à la source jusqu'à ce que l'activité d'écroûtage cesse. La DEL CLIP s'allume à 12 Vrms, 16 volts crête. L'entrée s'écroûte à 17 Vrms, 24 volts crête.

*L'indicateur d'activité s'allume à 5 mVrms ou -45 dBV.*

### 7. Commande De Limite De Courant De Ligne

La commande de limite de courant de ligne permet de réduire la puissance pour permettre un fonctionnement avec une disponibilité de puissance limitée. Les transitoires à pleine puissance seront permises, mais si la puissance moyenne est excessive, la puissance sera limitée. Cette commande fonctionne en faisant avancer le limiteur qui limite la température de la bobine mobile et en surveillant la consommation de courant. En position 5 ampères, la puissance moyenne est limitée uniquement par la température de la bobine mobile. En position 4 ampères, avec la plupart des programmes musicaux, le limiteur ne sera actif qu'occasionnellement, en fonction du contenu musical. En position 3 ampères, certains types de musique ne seront pas limités, principalement la musique sans basses profondes ou lorsque les basses ne sont pas traitées. La position 2 ampères réduira significativement la sortie lorsque le contenu musical contient des basses continues en dessous de 45 Hz. Le témoin vert de mise sous tension s'assombrit pour indiquer que le limiteur de courant de ligne est actif. Une faible gradation indique que le limiteur thermique avancé est actif, tandis qu'une gradation importante indique que le système de surveillance du courant de ligne a détecté un courant de ligne excessif. Une faible tension de ligne, généralement due à de longs cordons d'alimentation, peut provoquer un courant de ligne excessif. Le système de contrôle du courant de ligne empêche ce phénomène de déclencher les disjoncteurs de la source d'alimentation.

Pour obtenir le manuel de utilisateur visitez notre site Web à <http://www.yorkville.com/manuals/> ou, si vous avez besoin d'une version imprimée appelez-nous au 905-837-8777

**REAL Gear.  
REAL People.**



Canada  
Voice: (905) 837-8481  
Fax: (905) 837-8746

U.S.A.  
Voice: (716) 297-2920  
Fax: (716) 297-3689

[www.yorkville.com](http://www.yorkville.com)

Yorkville Sound  
550 Granite Court  
Pickering, Ontario  
L1W-3Y8 CANADA

Yorkville Sound Inc.  
4625 Witmer Industrial Estate  
Niagara Falls, New York  
14305 USA

# Yorkville Synergy Convenience Receptacle Installation (Cascade Installation)

## RATED CURRENT

Table 1 - SYNERGY RATED CURRENT

MAINS VOLTAGE	MODEL	RATED CURRENT (Arms)	LINE CURRENT <sup>a</sup> LIMIT SWITCH (Arms)		
			MAX	80%	60%
120V 60 Hz (NORTH AMERICA)	SA102	1.0			
	SA153	2.5			
	SA115S	3.0			
	SA221S	11.0	11.0	8.0	6.0
	SA315S	10.2	10.2	10.2	8.1
230V 50 Hz (EUROPE)	SA102	0.5			
	SA153	1.5			
	SA221SCE	6.3	6.3	4.0	3.0

<sup>a</sup> The LINE CURRENT LIMIT SWITCH allows the user to limit the maximum continuous current consumption to reduced values as shown.

**Tech Support:** If you have any questions concerning your SYNERGY equipment don't hesitate to contact [synergy@yorkville.com](mailto:synergy@yorkville.com)

## ELECTRICAL SAFETY

It is always important to connect **all** sound reinforcement equipment to ac mains supply circuits that have proper electrical safety grounds. Never break off the Earth Ground pin from a 3-prong plug. This pin provides personal protection from electrical shock and protection of the equipment from lightning strikes and electrostatic buildup. It is also required for EMC shielding. Replace the plug if the Earth Ground pin is missing.

1. Always connect the equipment to a circuit with a suitable electrical ground.
2. Do not overload the power cords and convenience outlets.
3. Always inspect the cords and plugs before use. Do not use outlets or cords that have exposed conductors, are worn or damaged. Replace electrical cords that have worn or damaged insulation and remember to pull the plug not the cord to prevent damage to the cord. Only replace with the equivalent heavy-duty cord supplied by the manufacturer.
4. The AC supply cord should be routed so that it is unlikely that it will be damaged. Protect the power cord from being walked on or pinched. If the AC supply cord is damaged DO NOT OPERATE THE UNIT. To completely disconnect this apparatus from the AC Mains, disconnect the power supply cord plug from the AC receptacle. The mains plug of the power supply cord shall remain readily accessible. Unplug the apparatus during lightning storms or when unused for long periods of time. Route cords away from traffic to avoid tripping hazards and unnecessary wear on the power cord.
5. Never Break Off the Third Prong on a Plug. Replace broken 3-prong plugs and make sure the third prong is properly grounded.
6. Keep line cords away from heat, water and oil. They can damage the insulation and create a shock hazard.
7. Do not tie cords in tight knots. Knots can cause short circuits and shocks. Loop the cords or use a twist lock plug.



**REAL Gear.**  
**REAL People.**

Canada  
Voice: (905) 837-8481  
Fax: (905) 837-8746

U.S.A.  
Voice: (716) 297-2920  
Fax: (716) 297-3689

[www.yorkville.com](http://www.yorkville.com)

**Yorkville Sound**  
550 Granite Court  
Pickering, Ontario  
L1W-3Y8 CANADA

**Yorkville Sound Inc.**  
4625 Witmer Industrial Estate  
Niagara Falls, New York  
14305 USA

# Installation d'Un Réceptacle de Commodité Yorkville Synergy (Installation en Cascade)

## COURANT NOMINAL

Tableau 1 - COURANT NOMINAL DE SYNERGIE

TENSION PRINCIPALE	MODÈLE	COURANT NOMINAL (Armes)	COURANT DE LIGNE <sup>a</sup> COMMUTATEUR DE LIMITEUR (Armes)		
			MAX	80%	60%
120V 60 Hz (AMÉRIQUE DU NORD)	SA102	1.0			
	SA153	2.5			
	SA115S	3.0			
	SA221S	11.0	11.0	8.0	6.0
	SA315S	10.2	10.2	10.2	8.1
230V 50 Hz (EUROPE)	SA102	0.5			
	SA153	1.5			
	SA221SCE	6.3	6.3	4.0	3.0

<sup>a</sup> Le commutateur LINE CURRENT LIMIT permet à l'utilisateur de limiter la consommation maximale de courant continu à des valeurs réduites comme indiqué.

**Support technique :** Si vous avez des questions concernant votre équipement SYNERGY, n'hésitez pas à contacter [synergy@yorkville.com](mailto:synergy@yorkville.com).

## SÉCURITÉ RELATIVE À L'ÉLECTRICITÉ

Il est toujours important de connecter **tous les** équipements de sonorisation à des circuits d'alimentation secteur dotés de mises à la terre de sécurité électrique appropriées. Ne coupez jamais la broche de mise à la terre d'une fiche à trois broches. Cette broche assure la protection des personnes contre les chocs électriques et la protection de l'équipement contre la foudre et l'accumulation d'électricité statique. Elle est également nécessaire pour le blindage CEM. Remplacez la fiche si la broche de mise à la terre est absente.

1. Connectez toujours l'équipement à un circuit avec une mise à la terre électrique appropriée.
2. Ne surchargez pas les cordons d'alimentation et les prises de courant.
3. Inspectez toujours les cordons et les fiches avant de les utiliser. N'utilisez pas de prises ou de cordons dont les conducteurs sont exposés, qui sont usés ou endommagés. Remplacez les cordons électriques dont l'isolation est usée ou endommagée et n'oubliez pas de tirer sur la fiche et non sur le cordon pour éviter d'endommager ce dernier. Ne remplacez le cordon électrique que par un cordon équivalent à usage intensif fourni par le fabricant.
4. Le cordon d'alimentation CA doit être acheminé de manière qu'il soit peu probable qu'il soit endommagé. Protégez le cordon d'alimentation pour qu'il ne soit pas piétiné ou pincé. Si le cordon d'alimentation CA est endommagé, NE PAS FAIRE FONCTIONNER L'APPAREIL. Pour déconnecter complètement cet appareil du secteur, débranchez la fiche du cordon d'alimentation de la prise de courant. La fiche du cordon d'alimentation doit rester facilement accessible. Débranchez l'appareil pendant les orages ou lorsqu'il n'est pas utilisé pendant de longues périodes. Acheminez les cordons à l'écart de la circulation pour éviter les risques de trébuchement et l'usure inutile du cordon d'alimentation.
5. Ne cassez jamais la troisième broche d'une fiche. Remplacez les fiches à trois broches cassées et assurez-vous que la troisième broche est correctement mise à la terre.
6. Gardez les cordons de ligne à l'écart de la chaleur, de l'eau et de l'huile. Ils peuvent endommager l'isolation et créer un risque de choc.
7. Ne faites pas de nœuds serrés avec les cordons. Les nœuds peuvent provoquer des courts-circuits et des chocs. Faites des boucles avec les cordons ou utilisez une fiche à verrouillage par torsion.



**REAL Gear.  
REAL People.**

**Canada**  
Voice: (905) 837-8481  
Fax: (905) 837-8746

**U.S.A.**  
Voice: (716) 297-2920  
Fax: (716) 297-3689

**www.yorkville.com**

**Yorkville Sound**  
550 Granite Court  
Pickering, Ontario  
L1W-3Y8 CANADA

**Yorkville Sound Inc.**  
4625 Witmer Industrial Estate  
Niagara Falls, New York  
14305 USA



## Yorkville Sound

550 Granite Court  
Pickering, Ontario  
Canada L1W 3Y8

Auto Attend: (905) 837-8550

Fax: (905) 837-8746

[www.yorkville.com](http://www.yorkville.com)

---