



**WEB:** [www.yorkville.com](http://www.yorkville.com)

#### **WORLD HEADQUARTERS**

##### **CANADA**

**Yorkville Sound Limited**  
550 Granite Court  
Pickering, Ontario  
L1W 3Y8 CANADA

Voice: 905-837-8481  
Fax: 905-839-5776

##### **U.S.A.**

**Yorkville Sound Inc.**  
4625 Witmer Industrial Estate  
Niagara Falls, New York  
14305, USA

Voice: 716-297-2920  
Fax: 716-297-3689



# ***SERVICE MANUAL***

## ***PSA 15S + PSA 18S***

#### **SMT Disclaimer**

Due to the complex nature of the use of SMT installed components in Yorkville equipment, we highly caution all service technicians in attempting to repair or replace SMT factory installed components.

Many of these components may be glued prior to initial soldering.

**Replacing SMT components requires expensive specialized de-soldering equipment and training.**

Yorkville Sound will repair and replace defective SMT components to ensure proper quality assurance and installation is maintained.

**Quality and Innovation Since 1963**  
Printed in Canada

PSA15S  
PSA18S

## IMPORTANT SAFETY INSTRUCTIONS

|   |  |  |  |
|---|--|--|--|
|  <p>This lightning flash with arrowhead symbol, within an equilateral triangle, is intended to alert the user to the presence of uninsulated "dangerous voltage" within the product's enclosure that may be of sufficient magnitude to constitute a risk of electric shock to persons.</p> <p>Ce symbole d'éclair avec tête de flèche dans un triangle équilatéral est prévu pour alerter l'utilisateur de la présence d'un «voltage dangereux» non-isolé à proximité de l'enceinte du produit qui pourrait être d'ampleur suffisante pour présenter un risque de choc électrique.</p> |  <p><b>CAUTION - AVIS</b><br/>RISK OF ELECTRIC SHOCK<br/>DO NOT OPEN<br/>RISQUE DE CHOC ELECTRIQUE<br/>NE PAS OUVRIIR</p> |  <p><b>DO NOT PUSH OR PULL</b></p>                                |  <p>The exclamation point within an equilateral triangle is intended to alert the user to the presence of important operating and maintenance (servicing) instructions in the literature accompanying the appliance.</p> <p>Le point d'exclamation à l'intérieur d'un triangle équilatéral est prévu pour alerter l'utilisateur de la présence d'instructions importantes dans la littérature accompagnant l'appareil en ce qui concerne l'opération et la maintenance de cet appareil.</p> |
|  <p>The DO NOT STACK symbol is intended to alert the user that the product shall not be vertically stacked because of the nature of the product.</p> <p>La symbole NE PAS EMPILER est pour alerter l'utilisateur que le produit ne doit pas être empilé verticalement en raison de la nature du produit.</p>  |  <p><b>SEPARATE COLLECTION WEEE</b></p>   |  <p><b>CAUTION: HOT SURFACE</b><br/>ATTENTION: SURFACE CHAUDE</p> |  <p><b>CAUTION: OVERHEAD LOAD</b><br/>ATTENTION: CHARGE AÉRIENNE</p>  |

### FOLLOW ALL INSTRUCTIONS

Instructions pertaining to a risk of fire, electric shock, or injury to a person

**CAUTION: TO REDUCE THE RISK OF ELECTRIC SHOCK, DO NOT REMOVE COVER (OR BACK). NO USER SERVICEABLE PARTS INSIDE. REFER SERVICING TO QUALIFIED SERVICE PERSONNEL.**

**Read Instructions:** The Owner's Manual should be read and understood before operation of your unit. Please, save these instructions for future reference and heed all warnings.

**Cleaning:** Clean only with dry cloth.

**Packaging:** Keep the box and packaging materials, in case the unit needs to be returned for service.

**Warning:** When using electric products, basic precautions should always be followed, including the following:

#### Power Sources

Your unit should be connected to a power source only of the voltage specified in the owners manual or as marked on the unit. This unit has a polarized plug. Do not use with an extension cord or receptacle unless the plug can be fully inserted. Precautions should be taken so that the grounding scheme on the unit is not defeated. An apparatus with CLASS I construction shall be connected to a Mains socket outlet with a protective earthing connection. Where the MAINS plug or an appliance coupler is used as the disconnect device, the disconnect device shall remain readily operable.

#### Hazards

Do not place this product on an unstable cart, stand, tripod, bracket or table. The product may fall, causing serious personal injury and serious damage to the product. Use only with cart, stand, tripod, bracket, or table recommended by the manufacturer or sold with the product. Follow the manufacturer's instructions when installing the product and use mounting accessories recommended by the manufacturer. Only use attachments/accessories specified by the manufacturer.

Equipment that is suspended overhead must use a secondary safeguard to prevent personal injury in the event the primary mounting mechanism fails. Safety eyebolts attached to the equipment and galvanized steel wire can be used together to implement a failsafe mounting thus ensuring the safety of the equipment and anyone positioned below the equipment.

Improper installation can result in bodily injury or death. If you are not qualified to attempt the installation get help from a professional structural rigger.

*Note: Prolonged use of headphones at a high volume may cause health damage to your ears.*

Terminals marked with the "lightning bolt" are hazardous live, the external wiring connected to these terminals require installation by an instructed person or the use of ready made leads or cords.

Ensure that proper ventilation is provided around the appliance. Do not install near any heat sources such as radiators, heat registers, stoves, or other apparatus (including amplifiers) that produce heat.

No naked flame sources, such as lighted candles, should be placed on the apparatus.

#### Power Cord

Do not defeat the safety purpose of the polarized or grounding-type plug. A polarized plug has two blades with one wider than the other. A grounding type plug has two blades and a third grounding prong. The wide blade or the third prong are provided for your safety. If the provided plug does not fit into your outlet, consult an electrician for replacement of the obsolete outlet. The AC supply cord should be routed so that it is unlikely that it will be damaged. Protect the power cord from being walked on or pinched particularly at plugs. If the AC supply cord is damaged DO NOT OPERATE THE UNIT. To completely disconnect this apparatus from the AC Mains, disconnect the power supply cord plug from the AC receptacle. The mains plug of the power supply cord shall remain readily operable.

Unplug this apparatus during lightning storms or when unused for long periods of time.

#### Service

The unit should be serviced only by qualified service personnel. Servicing is required when the apparatus has been damaged in any way, such as power-supply cord or plug is damaged, does not operate normally or has been dropped. Disconnect power before servicing!

### SUIVEZ TOUTES LES INSTRUCTIONS

Instructions relatives au risque de feu, choc électrique, ou blessures aux personnes

**AVIS: AFIN DE REDUIRE LES RISQUE DE CHOC ELECTRIQUE, N'ENLEVEZ PAS LE COUVERT (OU LE PANNEAU ARRIERE) NE CONTIENT AUCUNE PIECE REPARABLE PAR L'UTILISATEUR. CONSULTEZ UN TECHNICIEN QUALIFIE POUR L'ENTRETIEN .**

**Veillez Lire le Manuel:** Il contient des informations qui devraient être comprises avant l'opération de votre appareil. Conservez. Gardez S.V.P. ces instructions pour consultations ultérieures et observez tous les avertissements.

**Nettoyage:** Nettoyez seulement avec le tissu sec.

**Emballage:** Conservez la boîte au cas où l'appareil devrait être retourner pour réparation.

**Attention:** Lors de l'utilisation de produits électrique, assurez-vous d'adhérer à des précautions de bases incluant celle qui suivent:

**Alimentation -** L'appareil ne doit être branché qu'à une source d'alimentation correspondant au voltage spécifié dans le manuel ou tel qu'indiqué sur l'appareil. Cet appareil est équipé d'une prise d'alimentation polarisée. Ne pas utiliser cet appareil avec un cordon de raccordement à moins qu'il soit possible d'insérer complètement les trois lames. Des précautions doivent être prises afin d'éviter que le système de mise à la terre de l'appareil ne soit désengagé. Un appareil construit selon les normes de CLASS I devrait être raccordé à une prise murale d'alimentation avec connexion intacte de mise à la masse. Lorsqu'une prise de branchement ou un coupleur d'appareils est utilisée comme dispositif de débranchement, ce dispositif de débranchement devra demeurer pleinement fonctionnel avec raccordement à la masse.

**Risque -** Ne pas placer cet appareil sur un chariot, un support, un trépied ou une table instables. L'appareil pourrait tomber et blesser quelqu'un ou subir des dommages importants. Utiliser seulement un chariot, un support, un trépied ou une table recommandés par le fabricant ou vendus avec le produit. Suivre les instructions du fabricant pour installer l'appareil et utiliser les accessoires recommandés par le fabricant. Utilisez seulement les attachements/accessoires indiqués par le fabricant.

L'équipement suspendu au-dessus de la tête doit utiliser une protection secondaire pour éviter les blessures en cas de défaillance du mécanisme de montage principal. Les boulons à cell de sécurité fixés à l'équipement et le fil d'acier galvanisé peuvent être utilisés ensemble pour mettre en œuvre un montage à sécurité intégrée, assurant ainsi la sécurité de l'équipement et de toute personne placée sous l'équipement.

Une installation incorrecte peut entraîner des blessures corporelles ou la mort. Si vous n'êtes pas qualifié pour tenter l'installation, demandez l'aide d'un gréeur structurel professionnel.

*Remarque : L'utilisation prolongée d'écouteurs à un volume élevé peut nuire à la santé de vos oreilles.*

Il convient de ne pas placer sur l'appareil de sources de flammes nues, telles que des bougies allumées.

Assurez que l'appareil est fourni de la propre ventilation. Ne procédez pas à l'installation près de source de chaleur tels que radiateurs, registre de chaleur, fours ou autres appareils (incluant les amplificateurs) qui produisent de la chaleur.





Les dispositifs marqués d'une symbole "d'éclair" sont des parties dangereuses au toucher et que les câblages extérieurs connectés à ces dispositifs de connection extérieure doivent être effectués par un opérateur formé ou en utilisant des cordons déjà préparés.

**Cordon d'Alimentation -** Ne pas enlever le dispositif de sécurité sur la prise polarisée ou la prise avec tige de mise à la masse du cordon d'alimentation. Une prise polarisée dispose de deux lames dont une plus large que l'autre. Une prise avec tige de mise à la masse dispose de deux lames en plus d'une troisième tige qui connecte à la masse. La lame plus large ou la tige de mise à la masse est prévu pour votre sécurité. La prise murale est désuète si elle n'est pas conçue pour accepter ce type de prise avec dispositif de sécurité. Dans ce cas, contactez un électricien pour faire remplacer la prise murale. Évitez d'endommager le cordon d'alimentation. Protégez le cordon d'alimentation. Assurez-vous qu'on ne marche pas dessus et qu'on ne le pince pas en particulier aux prises. N'UTILISEZ PAS L'APPAREIL. Si le cordon d'alimentation est endommagé. Pour débrancher complètement cet appareil de l'alimentation CA principale, déconnectez le cordon d'alimentation de la prise d'alimentation murale. Le cordon d'alimentation du bloc d'alimentation de l'appareil doit demeurer pleinement fonctionnel.

Débranchez cet appareil durant les orages ou si inutilisé pendant de longues périodes.

**Service -** L'appareil ne doit être entretenu que par un personnel de service qualifié. Une réparation est nécessaire lorsque l'appareil a été endommagé de quelque manière que ce soit, comme le cordon d'alimentation ou la fiche est endommagé, ne fonctionne pas normalement . Débranchez l'alimentation avant l'entretien!

## IMPORTANT SAFETY INSTRUCTIONS

|  |   |
|--|---|
|  <p>The Lightning Flash with arrowhead symbol within an equilateral triangle, is intended to alert the user to the presence of uninsulated "dangerous voltage" within the product enclosure that may be of sufficient magnitude to constitute a risk of shock to persons</p> |  <p>Le symbole représentant un éclair avec une flèche à l'intérieur d'un triangle équilatéral est utilisé pour prévenir l'utilisateur de la présence d'une tension électrique dangereuse non isolée à l'intérieur de l'appareil. Cette tension est d'un niveau suffisamment élevé pour représenter un risque d'électrocution</p> |
|  <p>The exclamation point within an equilateral triangle is intended to alert the user to the presence of important operating and maintenance (servicing) instructions in the literature accompanying the product</p>  |  <p>Le symbole représentant un point d'exclamation à l'intérieur d'un triangle équilatéral, signale à l'utilisateur la présence d'instructions importantes relatives au fonctionnement et à l'entretien de l'appareil dans cette notice d'installation</p>   |

1. Read these instructions.
2. Keep these instructions.
3. Heed all warnings.
4. Follow all instructions.
5. Clean only with dry cloth.
6. Do not block any ventilation openings. Install in accordance with the manufacturer's instructions.
7. Do not install near any heat sources such as radiators, heat registers, stoves, or other apparatus (including amplifiers) that produce heat.
8. Do not defeat the safety purpose of the polarized or grounding-type plug. A polarized plug has two blades with one wider than the other. A grounding type plug has two blades and a third grounding prong. The wide blade or the third prongs are provided for your safety. If the provided plug does not fit into your outlet, consult an electrician for replacement of the obsolete outlet.
9. Protect the power cord from being walked on or pinched particularly at plugs, convenience receptacles, and the point where they exit from the apparatus.
10. Only use attachments/accessories specified by the manufacturer.
11. Use only with the cart, stand, tripod, bracket, or table specified by the manufacturer, or sold with the apparatus. When a cart is used, use caution when moving the cart/apparatus combination to avoid injury from tip-over.
12. Unplug this apparatus during lightning storms or when unused for long periods of time.
143. Refer all servicing to qualified service personnel. Servicing is required when the apparatus has been damaged in any way, such as power-supply cord or plug is damaged, does not operate normally, or has been dropped.

#### WARNING:

- To completely disconnect this apparatus from the ac mains, disconnect the power supply cord plug from the ac receptacle.
- The mains plug of the power supply cord or appliance coupler shall remain readily accessible.

#### AVERTISSEMENT:

- Pour isoler totalement cet appareil de l'alimentation secteur, débranchez totalement son cordon d'alimentation du réceptacle CA.
- La prise du cordon d'alimentation ou du prolongateur, si vous en utilisez un comme dispositif de débranchement, doit rester facilement accessible



**CAUTION**

**TO PREVENT ELECTRIC SHOCK HAZARD,  
DO NOT CONNECT TO MAINS POWER SUPPLY  
WHILE GRILLE IS REMOVED.**





**AVIS**

**POUR PRÉVENIR LES RISQUES D'ÉLECTROCUTION,  
NE PAS RACCORDER A L'ALIMENTATION ÉLECTRIQUE ALORS  
QUE LA GRILLE EST RETIRÉE.**



This equipment has been tested and found to comply with the limits for a Class A digital device, pursuant to part 15 of the FCC Rules. These limits are designed to provide reasonable protection against harmful interference when the equipment is operated in a commercial environment. This equipment generates, uses, and can radiate radio frequency energy and, if not installed and used in accordance with the instruction manual, may cause harmful interference to radio communications. Operation of this equipment in a residential area is likely to cause harmful interference in which case the user will be required to correct the interference at his own expense.

This device complies with ISED Canada's license-exempt RSS standard(s). Operation is subject to the following two conditions: (1) This device may not cause interference, and (2) This device must accept any interference, including interference that may cause undesired operation of the device.

Cet équipement a été testé et déclaré conforme aux limites d'un appareil numérique de classe A, conformément à la partie 15 des règles de la FCC. Ces limites sont conçues pour fournir une protection raisonnable contre les interférences nuisibles lorsque l'équipement est utilisé dans un environnement commercial. Cet équipement génère, utilise et peut émettre de l'énergie de radiofréquence et, s'il n'est pas installé et utilisé conformément au manuel d'instructions, peut causer des interférences nuisibles aux communications radio. L'utilisation de cet équipement dans une zone résidentielle est susceptible de provoquer des interférences nuisibles, auquel cas l'utilisateur devra corriger les interférences à ses propres frais.

Le présent appareil est conforme aux CNR ISDE Canada applicables aux appareils radio exempts de licence. L'exploitation est autorisée aux deux conditions suivantes: (1) l'appareil ne doit pas produire de brouillage, et (2) l'utilisateur de l'appareil doit accepter tout brouillage radioélectrique subi, même si le brouillage est susceptible d'en compromettre le fonctionnement.

TOTAL OF TWO PSA15S/PSA18S  
CABINETS CAN BE CONNECTED WHEN  
USING CASCADE POWER  
SEE OWNERS MANUAL  
FOR CASCADE INSTALLATION

120V~ 60Hz 4.5A  
STANDALONE  
12A MAX WITH  
AC OUTLET



7.5A MAX ON  
FIRST OUTLET

Circuit  
Breaker

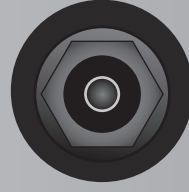

▼ Main In ▲ Main Out  
Full-Range

# PARALINE SERIES PSA15S

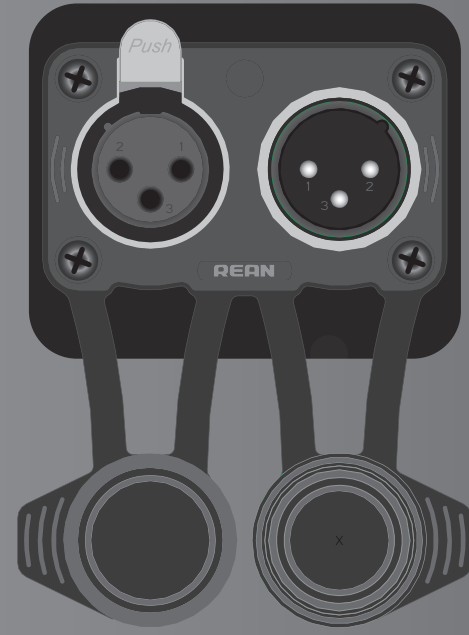

[www.yorkville.com](http://www.yorkville.com)



IP54  
RATED

PSA15S A-Z1967B / 1v3

SERIAL NUMBER

DESIGNED & MANUFACTURED BY  
YORKVILLE SOUND • TORONTO, CANADA



This device complies with Part 15 of the FCC Rules. Operation is subject to the following two conditions: (1) this device may not cause harmful interference, and (2) this device must accept any interference received, including interference that may cause undesired operation.  
CAN ICES-3 (A) / NMB-3 (A)

TOTAL OF TWO PSA18S/PSA18S  
CABINETS CAN BE CONNECTED WHEN  
USING CASCADE POWER  
SEE OWNERS MANUAL  
FOR CASCADE INSTALLATION

120V~ 60Hz 4.5A  
STANDALONE  
12A MAX WITH  
AC OUTLET



7.5A MAX ON  
FIRST OUTLET

Circuit  
Breaker



▼ Main In ▲ Main Out  
Full-Range

# PARALINE SERIES PSA18S

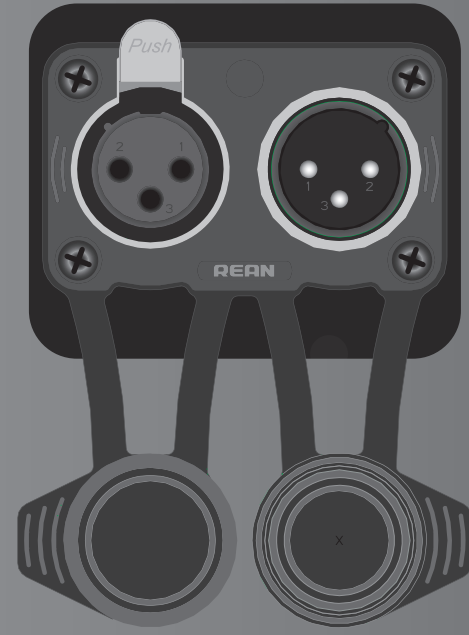

[www.yorkville.com](http://www.yorkville.com)



IP54  
RATED

PSA18S A-Z1967A | 1v3

SERIAL NUMBER

DESIGNED & MANUFACTURED BY  
YORKVILLE SOUND • TORONTO, CANADA



This device complies with Part 15 of the FCC Rules. Operation is subject to the following two conditions: (1) this device may not cause harmful interference, and (2) this device must accept any interference received, including interference that may cause undesired operation.  
CAN ICES-3 (A) / NMB-3 (A)

**Specifications**

|  | <b>PSA15S</b>  | <b>PSA18S</b>   |
|--|--|---|
| <b>System Type</b>                           | Bass Reflex  | Bass Reflex   |
| <b>Active or Passive</b>                     | Active   | Active  |
| <b>Program Power (watts)</b>                 | 1500 watts (3000 watts Peak)   | 1500 watts (3000 watts Peak)  |
| <b>Max SPL (dB)</b>                          | 135dB Peak (129dB Continuous)  | 137 dB Peak (131dB Continuous)  |
| <b>Frequency Response (Hz +/- 3dB)</b>       | 40-100   | 35-100  |
| <b>LF Driver(s)</b>                          | 15" Neo Woofer w/ 4" Voicecoil   | 18" Neo Woofer w/ 4" Voicecoil  |
| <b>LF Protection</b>                         | Thermal / Overcurrent (X-max) / Clip   | Thermal / Overcurrent (X-max) / Clip  |
| <b>Power Consumption (typ/max)</b>           | 120V 4.5A / 6.4A   | 120V 4.5A / 6.4A  |
| <b>In / Out Connections</b>                  | 1 x XLR Main In (Link) waterproof<br>1 x XLR Main Out (Link) waterproof  | 1 x XLR Main In (Link) waterproof<br>1 x XLR Main Out (Link) waterproof   |
| <b>Level Controls</b>                        | Level  | Level   |
| <b>LED Indicators</b>                        | Power, Limit and Clip  | Power, Limit and Clip   |
| <b>Other Controls / Features</b>             | 100Hz Low Pass Filter<br>10A resettable thermal breaker<br>Waterproof powerCON® TRUE1 In/Out<br>IP54 Rated - water and dust protection | 100Hz Low Pass Filter<br>10A resettable thermal breaker<br>Waterproof powerCON® TRUE1 In/Out<br>IP54 Rated - IP54 water and dust protection |
| <b>Wheels</b>                                | 4 x 4" back  | 4 x 4" back   |
| <b>Bar Handles</b>                           | 1 x left side, 1 x right side  | 1 x left side, 1 x right side   |
| <b>Pole Mount Adapter (1 3/8-inch-3.5cm)</b> | 1 top (1 3/8" / 3.5 cm)  | 1 top (1 3/8" / 3.5 cm)   |
| <b>Enclosure Materials</b>                   | 15mm (5/8") 11-ply Russian Birch   | 15mm (5/8") 11-ply Russian Birch  |
| <b>Covering / Finish</b>                     | Black Ultrathane Paint   | Black Ultrathane Paint  |
| <b>Dimensions (DWH x backW, inches)</b>      | 33 x 22 x 20.5   | 37 x 24.4 x 20.7  |
| <b>Dimensions (DWH x backW, cm)</b>          | 84 x 56 x 52   | 94 x 62 x 52  |
| <b>Weight (lbs/kg)</b>                       | 134 / 61   | 150 / 68  |

*Specifications subject to change without notice*

**Spécification**

|  | <b>PSA15S</b>   | <b>PSA18S</b>   |
|--|---|---|
| <b>Type de Système</b>                                     | Bass-Reflex   | Bass-Reflex   |
| <b>Actif ou Passif</b>                                     | Actif   | Actif   |
| <b>Puissance Nominale (watts)</b>                          | 1500 watts (3000 watts crête)   | 1500 watts (3000 watts crête)   |
| <b>Max SPL (dB)</b>  | 135dB crête (129dB Continu)   | 137 dB crête (131dB Continu)  |
| <b>Réponse en Fréquence (Hz +/- 3dB)</b>                   | 40-100  | 35-100  |
| <b>HP Basses Fréquences</b>                                | Woofers Neo 15 pouce avec bobine acoustique 4 pouce   | Woofers Neo 18 pouce avec bobine acoustique 4 pouce   |
| <b>Protection Basses Fréquences</b>                        | Thermique / Surintensité (X-max) / Clip   | Thermique / Surintensité (X-max) / Clip   |
| <b>Consommation de Puissance (typ/max)</b>                 | 120V 4.5A / 6.4A  | 120V 4.5A / 6.4A  |
| <b>Connexions Entrée / Sortie</b>                          | 1 x XLR Main In (Link) étanche<br>1 x XLR Main Out (Link) étanche   | 1 x XLR Main In (Link) étanche<br>1 x XLR Main Out (Link) étanche   |
| <b>Commandes de Niveau</b>                                 | Level   | Level   |
| <b>Indicateurs DEL</b>                                     | Power, Limit and Clip   | Power, Limit and Clip   |
| <b>Autres commandes / Caractéristiques</b>                 | Filtre passe-bas 100 Hz<br>Disjoncteur thermique réarmable 10A<br>Entrée/Sortie powerCON® TRUE1 étanche<br>Indice de protection IP54 - Protection contre l'eau et la poussière IP54 | Filtre passe-bas 100 Hz<br>Disjoncteur thermique réarmable 10A<br>Entrée/Sortie powerCON® TRUE1 étanche<br>Indice de protection IP54 - Protection contre l'eau et la poussière IP54 |
| <b>Roues</b>   | 4 x 4" Arrière  | 4 x 4" Arrière  |
| <b>Poignés</b>   | 1 x (Côté Gauche), 1 x (Côté Droit)   | 1 x (Côté Gauche), 1 x (Côté Droit)   |
| <b>Adaptateur de montage sur poteau (1 3/8-inch-3.5cm)</b> | 1 top (1 3/8" / 3.5 cm)   | 1 Dessus (1 3/8" / 3.5 cm)  |
| <b>Matériel de Construction</b>                            | 15mm (5/8") Bouleau Russe 11-plis   | 15mm (5/8") Bouleau Russe 11-plis   |
| <b>Finition</b>  | Peinture noire d'Ultrathane   | Peinture noire d'Ultrathane   |
| <b>Dimensions (PLH x L arrière, pouces)</b>                | 33 x 22 x 20.5  | 37 x 24.4 x 20.7  |
| <b>Dimensions (PLH x L arrière, cm)</b>                    | 84 x 56 x 52  | 94 x 62 x 52  |
| <b>Poids (livres/kg)</b>                                   | 134 / 61  | 150 / 68  |

*Spécifications sont sujettes à modification sans préavis*

# Block Diagram for Paralane Series Powered Subwoofers

DESIGNED & MANUFACTURED BY YORKVILLE SOUND

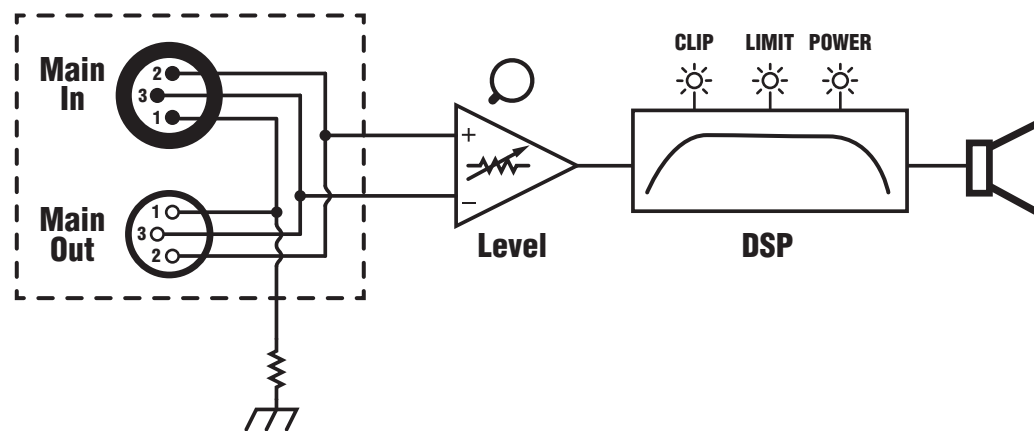

- NOTE: ALL LINK CONNECTIONS FUNCTION AS INPUTS OR OUTPUTS.

PSA15P  
PSA18P

M2448-04 Parts Reference List 2025-06-24

| REF    | YS #       | Description                         | REF  | YS #  | Description                         | REF   | YS # | Description                         |
|--------|------------|-------------------------------------|------|-------|-------------------------------------|-------|------|-------------------------------------|
| AI-SUB | M2448-59   | 1600W SUBAMP/SUPPLY PCB             | D309 |       | SMAZ18-13-F 18V0 1W0 5% SMT ZEN     | R234  |      | W100 182K 1% 0805 SMT RES           |
| BLANK  | M2448BLANK | 2 OZ 2SD 73.8SQIN 1PER AMP/PS       | D21  |       | SMAZ18-13-F 18V0 1W0 5% SMT ZEN     | R235  |      | W100 10K0 1% 0805 SMT RES           |
| C1     |            | 10N 50V 10%CAP 0805 SMT X7R         | F1   |       | FUSE FAST 0A5 250VDC 350AC SMT 3912 | R236  |      | W100 6K98 1% 0805 SMT RES           |
| C2     |            | 10N 50V 10%CAP 0805 SMT X7R         | F2   |       | FUSE FAST 0A5 250VDC 350AC SMT 3912 | R237  |      | W100 1R0 5% 2512 SMT RES            |
| C3     |            | 10N 50V 10%CAP 0805 SMT X7R         | F301 |       | FUSE SLOW 7A 125V SMT 6125          | R238  |      | W100 100R 1% 0805 SMT RES           |
| C4     | 6037       | 100N 1250V 10%CAP BLK RAD POLY FLM  | F302 |       | FUSE SLOW 7A 125V SMT 6125          | R240  |      | W100 475R 1% 0805 SMT RES           |
| C203   |            | 100N 50V 5%CAP 0805 SMT X7R         | HS1  | 4233  | 22X17X2MM ALN CERAMIC T0247 INSUL   | R241  |      | 1W00 27R0 1% 2512 SMT RES           |
| C204   |            | 100N 50V 5%CAP 0805 SMT X7R         | HS2  | 4233  | 22X17X2MM ALN CERAMIC T0247 INSUL   | R242  |      | 2W00 0R02 1% OARS SMT RES           |
| C205   |            | 100N 50V 5%CAP 0805 SMT X7R         | HS3  | Z1963 | PSA18S/15S HEAT SPREADER            | R243  |      | 2W00 0R05 1% OARS SMT RES           |
| C206   |            | 100N 50V 5%CAP 0805 SMT X7R         | HW1  | 8871  | 4-40X5/8 PAN PHILIPS MS BLACK ZINC  | R247  |      | W125 4K7 5% 0805 SMT RES            |
| C207   |            | 100N 50V 5%CAP 0805 SMT X7R         | HW2  | 8902  | 4-40X3/4 PAN PHILIPS MS TBZ         | R248  |      | 1W00 2R0 1% 2512 SMT RES            |
| C209   |            | 100N 50V 5%CAP 0805 SMT X7R         | HW3  | 8871  | 4-40X5/8 PAN PHILIPS MS BLACK ZINC  | R249  |      | W250 22R 5% 1206 SMT RES            |
| C210   |            | 100N 50V 5%CAP 0805 SMT X7R         | HW4  | 8485  | #6 SPLIT WASHER ZINC                | R250  |      | W250 1R 5% 1206 SMT RES             |
| C211   |            | 100N 50V 5%CAP 0805 SMT X7R         | HW5  | 3501  | COMPRESSION WASHER                  | R251  |      | W125 4K7 5% 0805 SMT RES            |
| C213   |            | 680P 50V 5%CAP 0805 SMT C0G         | HW7  | 8835  | 6-32X1/2 PAN QUAD MS TIN PLATE      | R252  |      | W100 1M0 1% 0805 SMT RES            |
| C214   |            | 470N 50V 5%CAP 1206 SMT X7R         | HW8  | 8800  | 6-32 KEPS NUT ZINC                  | R253  |      | W100 150R 5% 0805 SMT RES           |
| C215   |            | 1U 50V 20%CAP 4.3X3.9 SMT ELC       | HW9  | 8871  | 4-40X5/8 PAN PHILIPS MS BLACK ZINC  | R254  |      | W100 10K0 1% 0805 SMT RES           |
| C216   |            | 1N 50V 5%CAP 0805 SMT NPO           | HW10 | 8902  | 4-40X3/4 PAN PHILIPS MS TBZ         | R255  |      | W125 82K5 1% 0805 SMT RES           |
| C217   |            | 470P 50V 5%CAP 0603 SMT NPO         | HW11 | 8837  | 6-32 X 1/2 PAN PHILIP MS TBZ        | R256  |      | W125 82K5 1% 0805 SMT RES           |
| C218   |            | 1N 50V 5%CAP 0805 SMT NPO           | HW12 | 8800  | 6-32 KEPS NUT ZINC                  | R257  |      | W125 4K7 5% 0805 SMT RES            |
| C219   | 5972       | 680N 400V 5%CAP BLK RAD POLY FLM    | HW13 | 8701  | 4-40 KEPS NUT ZINC                  | R258  |      | W100 20K5 1% 0805 SMT RES           |
| C220   |            | 220N 50V 10%CAP 1206 SMT X7R        | HW14 | 8701  | 4-40 KEPS NUT ZINC                  | R259  |      | W100 182K 1% 0805 SMT RES           |
| C221   |            | 100N 100V 10%CAP 1206 SMT X7R       | HW15 | 8701  | 4-40 KEPS NUT ZINC                  | R260  |      | 470K 5% THERMISTOR NTC 0805 SMT     |
| C222   | 5986       | 100U 50VDC 5%CAP BLK MPOLYP FLM     | HW16 | 8701  | 4-40 KEPS NUT ZINC                  | R261  |      | W100 274K 1% 0805 SMT RES           |
| C223   | 5962       | 2U2 140AC10%CAP BLK RAD POLYP FLM   | HW17 | 8485  | #6 SPLIT WASHER ZINC                | R262  |      | W100 274K 1% 0805 SMT RES           |
| C224   |            | 1U 50V 20%CAP 4.3X3.9 SMT ELC       | HW18 | 3501  | COMPRESSION WASHER                  | R263  |      | W100 13K 1% 0805 SMT RES            |
| C225   |            | 470P 50V 5%CAP 0603 SMT NPO         | HW21 | 3501  | COMPRESSION WASHER                  | R264  |      | W125 1K4 1% 0805 SMT RES            |
| C226   |            | 47N 100V 10%CAP 1206 SMT X7R        | HW23 | 8701  | 4-40 KEPS NUT ZINC                  | R265  |      | W250 330R 5% 1206 SMT RES           |
| C227   |            | 100N 50V 5%CAP 0805 SMT X7R         | L200 | 6699  | 453UH CHOKE 91T14.5AWG/79912CORE    | R266  |      | 1W00 100K 5% 2512 SMT RES           |
| C228   | 5972       | 680N 400V 5%CAP BLK RAD POLY FLM    | L202 |       | 1000UH 10% COIL 12MM SMT            | R267  |      | 1W00 100K 5% 2512 SMT RES           |
| C229   | 5225       | 470P 1600V 20%CAP POLYPROP BULK     | L401 |       | 486UH COIL COMMON MODE 8A SMT       | R268  |      | W125 4K02 0.1% 0805 SMT RES         |
| C230   |            | 47P 50V 5%CAP 0805 SMT NPO          | Q1   |       | MMBTA92 PNP SOT-23 SMT              | SNL1  | 8372 | 1 MIL POLYIMIDE LABEL .375" X .375" |
| C231   |            | 100N 50V 5%CAP 0805 SMT X7R         | Q2   |       | IRFR825TRPBF NCH MFET DPAK3 SMT TS  | U200  |      | LTV-8141S ACINPUT OPTOCOUPLER SMT   |
| C232   |            | 33U 25V 20%CAP 6.3X5.5 SMT EL       | Q3   |       | MMBTA42 NPN SOT-23 SMT              | U201  |      | LM311 COMPARATOR IC SMT SO-8        |
| C233   |            | 100N 50V 5%CAP 0805 SMT X7R         | Q200 |       | MMBTA92 PNP SOT-23 SMT              | U202  |      | LM311 COMPARATOR IC SMT SO-8        |
| C234   |            | 100N 50V 5%CAP 0805 SMT X7R         | Q201 |       | MMBF4391LT1 NCH JFET SOT-23 SMT T&R | U203  |      | IRS21844SPBF IC HILO FET DRVR SO14  |
| C235   |            | 10U 16V 10%CAP 1206 SMT X7R         | Q203 | 2321  | IKW75N65EH5 T0247 NPN 75A IGB3      | U204  |      | 33078 DUAL OPAMP SMT SO-8           |
| C236   |            | 100N 50V 5%CAP 0805 SMT X7R         | Q204 |       | MMBTA92 PNP SOT-23 SMT              | U205  |      | 33078 DUAL OPAMP SMT SO-8           |
| C237   |            | 1U 25V 20%CAP 1206 SMT X7R          | Q205 | 2321  | IKW75N65EH5 T0247 NPN 75A IGB3      | U206  |      | TL331 COMPARATOR IC SMT SOT235      |
| C238   |            | 4U7 50V 10%CAP 1210 SMT CER         | R3   |       | W250 100K 5% 1206 SMT RES           | U207  |      | LNK302G OFFLINE SWITCH SMT SMD8B    |
| C239   |            | 3U9 250V 20%CAP 8X10 SMT ELE(YS5470 | R4   |       | W250 1M0 1% 1206 SMT RES            | U208  |      | ZXGD3006E6Q GATE DRVR 10A SMT SOT26 |
| C241   |            | 4U7 50V 10%CAP 1210 SMT CER         | R5   |       | W125 1K54 1% 0805 SMT RES           | U209  |      | ZXGD3006E6Q GATE DRVR 10A SMT SOT26 |
| C242   |            | 10U 16V 10%CAP 1206 SMT X7R         | R6   |       | W125 1K54 1% 0805 SMT RES           | U302  | 6856 | NJM7815FA TO220 P 15V0 REG IS V1    |
| C301   |            | 100N 100V 10%CAP 1206 SMT X7R       | R7   |       | W100 2K32 1% 0805 SMT RES           | U303  | 6857 | L7915CP TO220 N 15V0 REG IS V2      |
| C303   | 5887       | 2200U 50V 20%CAP BLK 18X27MM EL     | R8   |       | W100 2K32 1% 0805 SMT RES           | W201  | 2328 | 8 CIR XH-HEADER 0.098IN             |
| C304   |            | 4U7 25V 20%CAP 4X5.5 SMT ELC        | R9   |       | W100 1K0 1% 0805 SMT RES            | W304  | 4146 | 3 PIN POWER PIN HEADER MALE POLZED  |
| C306   |            | 100N 100V 10%CAP 1206 SMT X7R       | R11  |       | W125 100K0 1% 0805 SMT RES          | W307  | 4151 | 4 PIN POWER PIN HEADER MALE POLZED  |
| C307   | 5887       | 2200U 50V 20%CAP BLK 18X27MM EL     | R12  |       | W250 1M0 1% 1206 SMT RES            | W402  | 4215 | CONN HEADER STRAIGHT PIN 4POS 0.156 |
| C308   |            | 4U7 25V 20%CAP 4X5.5 SMT ELC        | R13  | 5186  | 35W0 10K 1% TO220 BULK RES          | 2D200 |      | MM3Z18VT1G 18V0 0W2 5% SMT ZEN      |
| C311   | 5923       | 3300U 250V 10%CAP BLK 40X80MM 4PS   | R14  |       | W250 1M0 1% 1206 SMT RES            |       |      |                                     |
| C312   | 5923       | 3300U 250V 10%CAP BLK 40X80MM 4PS   | R15  |       | W250 1M0 1% 1206 SMT RES            |       |      |                                     |
| C313   | 5923       | 3300U 250V 10%CAP BLK 40X80MM 4PS   | R16  |       | W125 100K0 1% 0805 SMT RES          |       |      |                                     |
| C314   | 5923       | 3300U 250V 10%CAP BLK 40X80MM 4PS   | R200 |       | W250 10R 5% 1206 SMT RES            |       |      |                                     |
| C316   | 5242       | 100N 250V 20%CAP BLK 'X2' 15MM AC   | R201 |       | W100 12K1 1% 0603 SMT RES           |       |      |                                     |
| C401   |            | 150P 1000V 5%CAP 1206 SMT C0G       | R202 |       | W250 10R 5% 1206 SMT RES            |       |      |                                     |
| C402   |            | 150P 1000V 5%CAP 1206 SMT C0G       | R203 |       | W100 10K0 1% 0805 SMT RES           |       |      |                                     |
| D1     |            | 3SMAJ5932B 20V 3W0 DO214AC SMT ZEN  | R204 |       | W100 12K1 1% 0603 SMT RES           |       |      |                                     |
| D2     |            | 3SMAJ5932B 20V 3W0 DO214AC SMT ZEN  | R206 |       | 1W00 100K 5% 2512 SMT RES           |       |      |                                     |
| D200   |            | CDSF4148 75V 0A15 1005 SMT          | R207 |       | W100 1K0 1% 0805 SMT RES            |       |      |                                     |
| D201   |            | BZX84C22 22V0 0W3 5% SMT ZEN        | R208 |       | W125 4M7 5% 0805 SMT RES            |       |      |                                     |
| D203   |            | BAT750 SOT-23 SMT SCHTKY            | R209 |       | 1W00 100K 5% 2512 SMT RES           |       |      |                                     |
| D204   |            | ES1J 600V 1A0 DO214AC SMT SMA       | R210 |       | W100 6K98 1% 0805 SMT RES           |       |      |                                     |
| D205   |            | ES1J 600V 1A0 DO214AC SMT SMA       | R212 |       | W100 10K0 1% 0805 SMT RES           |       |      |                                     |
| D206   |            | BAT750 SOT-23 SMT SCHTKY            | R213 |       | W100 182K 1% 0805 SMT RES           |       |      |                                     |
| D207   |            | CDSF4148 75V 0A15 1005 SMT          | R214 |       | W125 4K7 5% 0805 SMT RES            |       |      |                                     |
| D208   |            | ES1J 600V 1A0 DO214AC SMT SMA       | R215 |       | W125 47K5 1% 0805 SMT RES           |       |      |                                     |
| D209   |            | BZX84C43 43V0 0W3 5% SMT ZEN        | R218 |       | W125 8K66 1% 0805 SMT RES           |       |      |                                     |
| D210   |            | DIODE 400V 2A 35NS DO214AC SMT      | R219 |       | W100 475R 1% 0805 SMT RES           |       |      |                                     |
| D211   |            | DIODE 400V 2A 35NS DO214AC SMT      | R221 |       | W100 475R 1% 0805 SMT RES           |       |      |                                     |
| D212   |            | ES1J 600V 1A0 DO214AC SMT SMA       | R222 |       | W100 10K0 1% 0805 SMT RES           |       |      |                                     |
| D213   |            | BZX84C15L1 15V0 0W225 ZEN SOT23     | R223 |       | W100 6K98 1% 0805 SMT RES           |       |      |                                     |
| D214   |            | CDSF4148 75V 0A15 1005 SMT          | R224 |       | W125 47R 5% 0805 SMT RES            |       |      |                                     |
| D300   | 6852       | BRIDGE 45A 600V WIRE LEAD SIP       | R225 |       | W250 22R 5% 1206 SMT RES            |       |      |                                     |
| D301   |            | ES1J 600V 1A0 DO214AC SMT SMA       | R226 |       | W100 15K0 1% 0805 SMT RES           |       |      |                                     |
| D302   |            | MURS120T3 200V 1A DIO DO214AA SMT   | R227 |       | W100 1M0 1% 0805 SMT RES            |       |      |                                     |
| D304   |            | ES1J 600V 1A0 DO214AC SMT SMA       | R228 |       | W250 1R 5% 1206 SMT RES             |       |      |                                     |
| D305   |            | MURS120T3 200V 1A DIO DO214AA SMT   | R230 |       | W125 4K02 0.1% 0805 SMT RES         |       |      |                                     |
| D306   |            | MURS120T3 200V 1A DIO DO214AA SMT   | R231 |       | W100 1K0 1% 0805 SMT RES            |       |      |                                     |
| D307   |            | MURS120T3 200V 1A DIO DO214AA SMT   | R232 |       | W100 1K0 1% 0805 SMT RES            |       |      |                                     |
| D308   |            | SMAZ18-13-F 18V0 1W0 5% SMT ZEN     | R233 |       | W100 150R 5% 0805 SMT RES           |       |      |                                     |

M2449-02 Parts Reference List 2025-06-24

| REF    | YS #       | Description                        | REF  | YS # | Description                         | REF | YS # | Description |
|--------|------------|------------------------------------|------|------|-------------------------------------|-----|------|-------------|
| AI-ASS | M2449-59   | PSA15S/18S INPUT DSP PCB           | R18  |      | W100 100R 1% 0805 SMT RES           |     |      |             |
| C1     |            | 470P 250V 5%CAP 0603 SMT NP0       | R19  |      | W063 49R9 1% 0603 SMT RES           |     |      |             |
| C2     |            | 470P 250V 5%CAP 0603 SMT NP0       | R20  |      | W063 49R9 1% 0603 SMT RES           |     |      |             |
| C3     |            | 10N 250V 10%CAP 0805 SMT X7R       | R22  |      | W100 13K 1% 0805 SMT RES            |     |      |             |
| C4     |            | 1N 250V 10%CAP 0805 SMT X7R        | R24  |      | W125 10K00 0.1% 0805 SMT RES        |     |      |             |
| C5     |            | 10U 16V 20%CAP 0805 SMT X5R        | R25  |      | W125 10K00 0.1% 0805 SMT RES        |     |      |             |
| C6     |            | 680U 6V3 20%CAP 8X10 SMT ELE       | R27  |      | W100 499R 1% 0805 SMT RES           |     |      |             |
| C7     |            | 10U 16V 20%CAP 0805 SMT X5R        | R30  |      | W100 2K32 1% 0805 SMT RES           |     |      |             |
| C8     |            | 10U 16V 20%CAP 0805 SMT X5R        | R31  |      | W100 1K0 1% 0805 SMT RES            |     |      |             |
| C9     |            | 470N 50V 10%CAP 0805 SMT X7R       | R32  |      | W100 2K0 1% 0805 SMT RES            |     |      |             |
| C10    |            | 100N 50V 5%CAP 0805 SMT X7R        | R33  |      | W100 100R 1% 0805 SMT RES           |     |      |             |
| C11    |            | 100N 50V 5%CAP 0805 SMT X7R        | R37  |      | W100 100R 1% 0805 SMT RES           |     |      |             |
| C12    |            | 100N 50V 5%CAP 0805 SMT X7R        | R38  |      | W100 100R 1% 0805 SMT RES           |     |      |             |
| C13    |            | 100N 50V 5%CAP 0805 SMT X7R        | R44  |      | W125 4K7 5% 0805 SMT RES            |     |      |             |
| C14    |            | 100N 50V 5%CAP 0805 SMT X7R        | R46  |      | W100 82K5 1% 0603 SMT RE            |     |      |             |
| C15    |            | 100N 50V 5%CAP 0805 SMT X7R        | R47  |      | W100 82K5 1% 0603 SMT RE            |     |      |             |
| C16    |            | 100N 50V 5%CAP 0805 SMT X7R        | R48  |      | W125 1K50 1% 0805 SMT RES           |     |      |             |
| C17    |            | 10U 16V 10%CAP 1206 SMT X7R        | R49  |      | W125 1K50 1% 0805 SMT RES           |     |      |             |
| C18    |            | 10U 16V 20%CAP 0805 SMT X5R        | R51  |      | W125 47R 5% 0805 SMT RES            |     |      |             |
| C19    |            | 100N 50V 5%CAP 0805 SMT X7R        | R53  |      | W100 2K0 1% 0805 SMT RES            |     |      |             |
| C20    |            | 100N 50V 5%CAP 0805 SMT X7R        | R56  |      | W100 392R 1% 0805 SMT RES           |     |      |             |
| C21    |            | 100N 50V 5%CAP 0805 SMT X7R        | R107 |      | W100 19K6 1% 0603 SMT RES           |     |      |             |
| C22    |            | 10U 16V 20%CAP 0805 SMT X5R        | R115 |      | W100 82K5 1% 0603 SMT RE            |     |      |             |
| C23    |            | 100N 50V 5%CAP 0805 SMT X7R        | R124 |      | W100 82K5 1% 0603 SMT RE            |     |      |             |
| C24    |            | 10U 16V 20%CAP 0805 SMT X5R        | R164 |      | W100 1K0 1% 0805 SMT RES            |     |      |             |
| C25    |            | 10U 16V 20%CAP 0805 SMT X5R        | R165 |      | W100 31.6K 1% 0603 SMT RE           |     |      |             |
| C26    |            | 100N 50V 5%CAP 0805 SMT X7R        | R176 |      | W125 3K32 1% 0805 SMT RES           |     |      |             |
| C27    |            | 10U 16V 20%CAP 0805 SMT X5R        | R177 |      | W063 47K 1% 0603 SMT RES            |     |      |             |
| C28    |            | 100N 50V 5%CAP 0805 SMT X7R        | R181 |      | W100 31.6K 1% 0603 SMT RE           |     |      |             |
| C29    |            | 100N 50V 5%CAP 0805 SMT X7R        | SNL1 | 8372 | 1 MIL POLYIMIDE LABEL,.375" X .375" |     |      |             |
| C30    |            | 100N 50V 5%CAP 0805 SMT X7R        | U2   |      | LMR54410_SSWITCH 1A IC SMT SOT23-6  |     |      |             |
| C31    |            | 10U 16V 20%CAP 0805 SMT X5R        | U3   |      | AK4558 32BIT CODEC SMT QFN28        |     |      |             |
| C32    |            | 100N 50V 5%CAP 0805 SMT X7R        | U4   |      | MK10DN512V1K10 100MHZ MCU IC LQFP80 |     |      |             |
| C34    |            | 100N 50V 5%CAP 0805 SMT X7R        | U5   |      | NCP115ASN330T2G LD VREG 3V3 SOT23-5 |     |      |             |
| C35    |            | 10U 16V 20%CAP 0805 SMT X5R        | U6   |      | NCP115ASN330T2G LD VREG 3V3 SOT23-5 |     |      |             |
| C36    |            | 10U 16V 20%CAP 0805 SMT X5R        | U7   |      | IC OPA1678 OPAMP DUAL SO8 SMT       |     |      |             |
| C38    |            | 100N 50V 5%CAP 0805 SMT X7R        | U8   |      | IC OPA1678 OPAMP DUAL SO8 SMT       |     |      |             |
| C39    |            | 100N 50V 5%CAP 0805 SMT X7R        | U9   |      | IC OPA1678 OPAMP DUAL SO8 SMT       |     |      |             |
| C41    |            | 10U 16V 20%CAP 0805 SMT X5R        | W1   | 2344 | 8 CIR XH-HEADER RA 0.098IN          |     |      |             |
| C42    |            | 100N 50V 5%CAP 0805 SMT X7R        | W2   | 2369 | 3 CIR PH-HEADER 2MM                 |     |      |             |
| C43    |            | 33P 100V 5%CAP 0603 SMT COG        | W3   |      | 10 CIR DUAL ROW HDR 0.05 SPC SMT    |     |      |             |
| C44    |            | 33P 100V 5%CAP 0603 SMT COG        | W4   | 2369 | 3 CIR PH-HEADER 2MM                 |     |      |             |
| C45    |            | 15P 50V 5%CAP 0603 SMT NPO         | ZD1  |      | MM3Z18VT1G 18V0 0W2 5% SMT ZEN      |     |      |             |
| C46    |            | 10U 16V 20%CAP 0805 SMT X5R        | ZD2  |      | MM3Z18VT1G 18V0 0W2 5% SMT ZEN      |     |      |             |
| C47    |            | 100N 50V 5%CAP 0805 SMT X7R        |      |      |                                     |     |      |             |
| C48    |            | 10U 16V 10%CAP 1206 SMT X7R        |      |      |                                     |     |      |             |
| C55    |            | 100U 25V 20%CAP 8X5.4 SMT ELE      |      |      |                                     |     |      |             |
| C134   |            | 100N 50V 5%CAP 0805 SMT X7R        |      |      |                                     |     |      |             |
| C135   |            | 100N 50V 5%CAP 0805 SMT X7R        |      |      |                                     |     |      |             |
| D10    |            | CDSF4148 75V 0A15 1005 SMT         |      |      |                                     |     |      |             |
| D11    |            | CDSF4148 75V 0A15 1005 SMT         |      |      |                                     |     |      |             |
| D39    |            | CDSF4148 75V 0A15 1005 SMT         |      |      |                                     |     |      |             |
| D40    |            | CDSF4148 75V 0A15 1005 SMT         |      |      |                                     |     |      |             |
| L2     |            | 15.0UH COIL 0805 SMT               |      |      |                                     |     |      |             |
| L3     |            | 12UH COIL 4A 0R04 10MMSQ SMT       |      |      |                                     |     |      |             |
| L6     |            | 8.2UH COIL 1210 SMT                |      |      |                                     |     |      |             |
| L7     |            | 8.2UH COIL 1210 SMT                |      |      |                                     |     |      |             |
| L10    |            | 15.0UH COIL 0805 SMT               |      |      |                                     |     |      |             |
| L11    |            | 15.0UH COIL 0805 SMT               |      |      |                                     |     |      |             |
| L12    |            | 15.0UH COIL 0805 SMT               |      |      |                                     |     |      |             |
| L13    |            | 15.0UH COIL 0805 SMT               |      |      |                                     |     |      |             |
| LD1    |            | GRN LED 2V8 20MA 1206 SMT          |      |      |                                     |     |      |             |
| LD2A   |            | RED LED 1V5 20MA 1206 SMT          |      |      |                                     |     |      |             |
| LD3A   |            | RED LED 1V5 20MA 1206 SMT          |      |      |                                     |     |      |             |
| LD4A   |            | YEL LED 1V7 20MA 1206 SMT          |      |      |                                     |     |      |             |
| PCB1   | M2449BLANK | 1 OZ 2SD 40.41SQIN 4PER PSA15S/18S |      |      |                                     |     |      |             |
| PTC1   | 6543       | 48R 265V RESETTABLE THERMISTOR PTC |      |      |                                     |     |      |             |
| R2     |            | W100 115K 1% 0805 SMT RE           |      |      |                                     |     |      |             |
| R3     |            | W125 22K1 1% 0805 SMT RES          |      |      |                                     |     |      |             |
| R4     |            | W125 37K4 1% 0805 SMT RES          |      |      |                                     |     |      |             |
| R5     |            | W100 19K6 1% 0603 SMT RES          |      |      |                                     |     |      |             |
| R6     |            | W100 10K0 1% 0603 SMT RES          |      |      |                                     |     |      |             |
| R7     |            | W100 499R 1% 0805 SMT RES          |      |      |                                     |     |      |             |
| R9     |            | W100 499R 1% 0805 SMT RES          |      |      |                                     |     |      |             |
| R10    |            | W125 1K5 5% 0805 SMT RES           |      |      |                                     |     |      |             |
| R11    |            | W125 470R 5% 0805 SMT RES          |      |      |                                     |     |      |             |
| R12    |            | W100 10K0 1% 0603 SMT RES          |      |      |                                     |     |      |             |
| R13    |            | W100 392R 1% 0805 SMT RES          |      |      |                                     |     |      |             |
| R14    |            | W125 47R 5% 0805 SMT RES           |      |      |                                     |     |      |             |
| R16    |            | W100 2K0 1% 0805 SMT RES           |      |      |                                     |     |      |             |



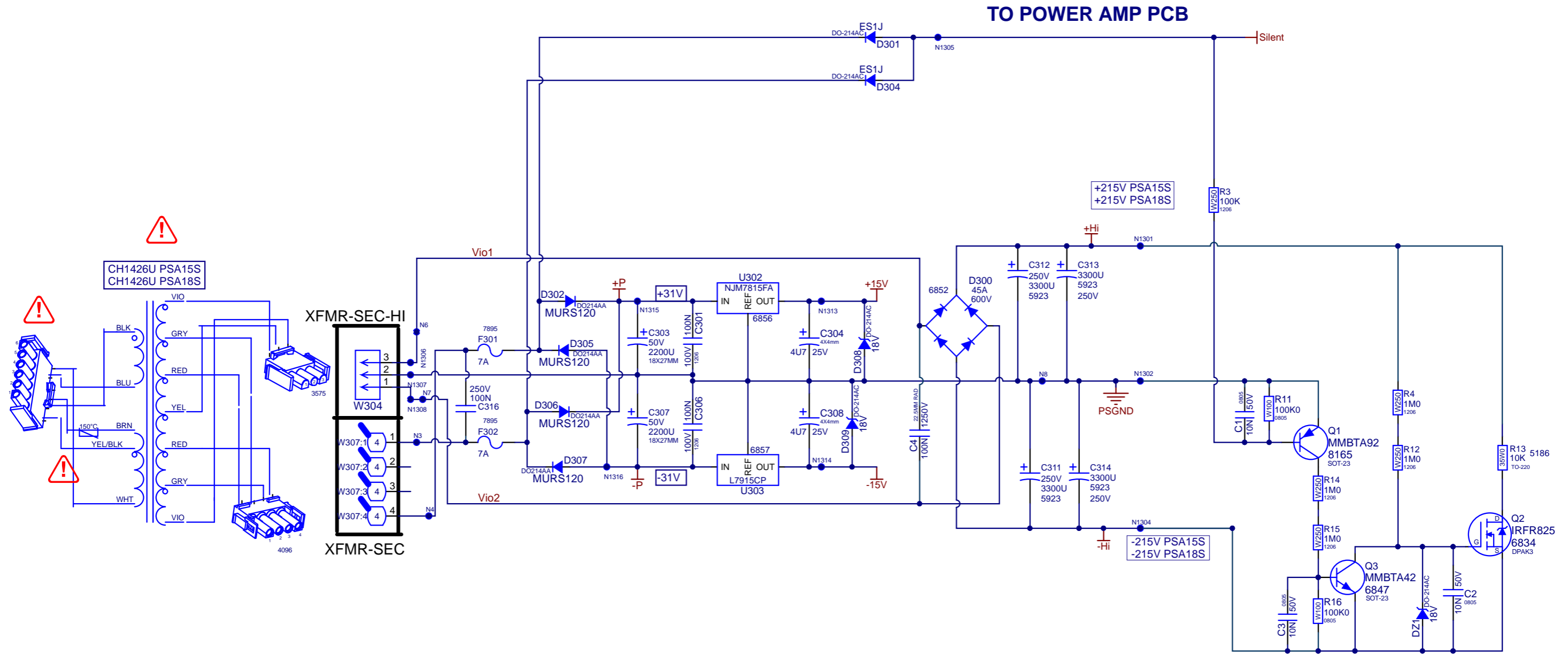

TO POWER AMP PCB



|                               |                     |
|-------------------------------|---------------------|
| Section: <b>Power Supply</b>  |                     |
| Product(s): <b>PSA15S/18S</b> |                     |
| PCB#: M2448                   | Rev#: V01           |
| Eng: G. Giurgea               | Sheet 1 Of 3        |
| Modified: 2025-03-03          | File: Supply.SCHDOC |

# SUBWOOFER AMP

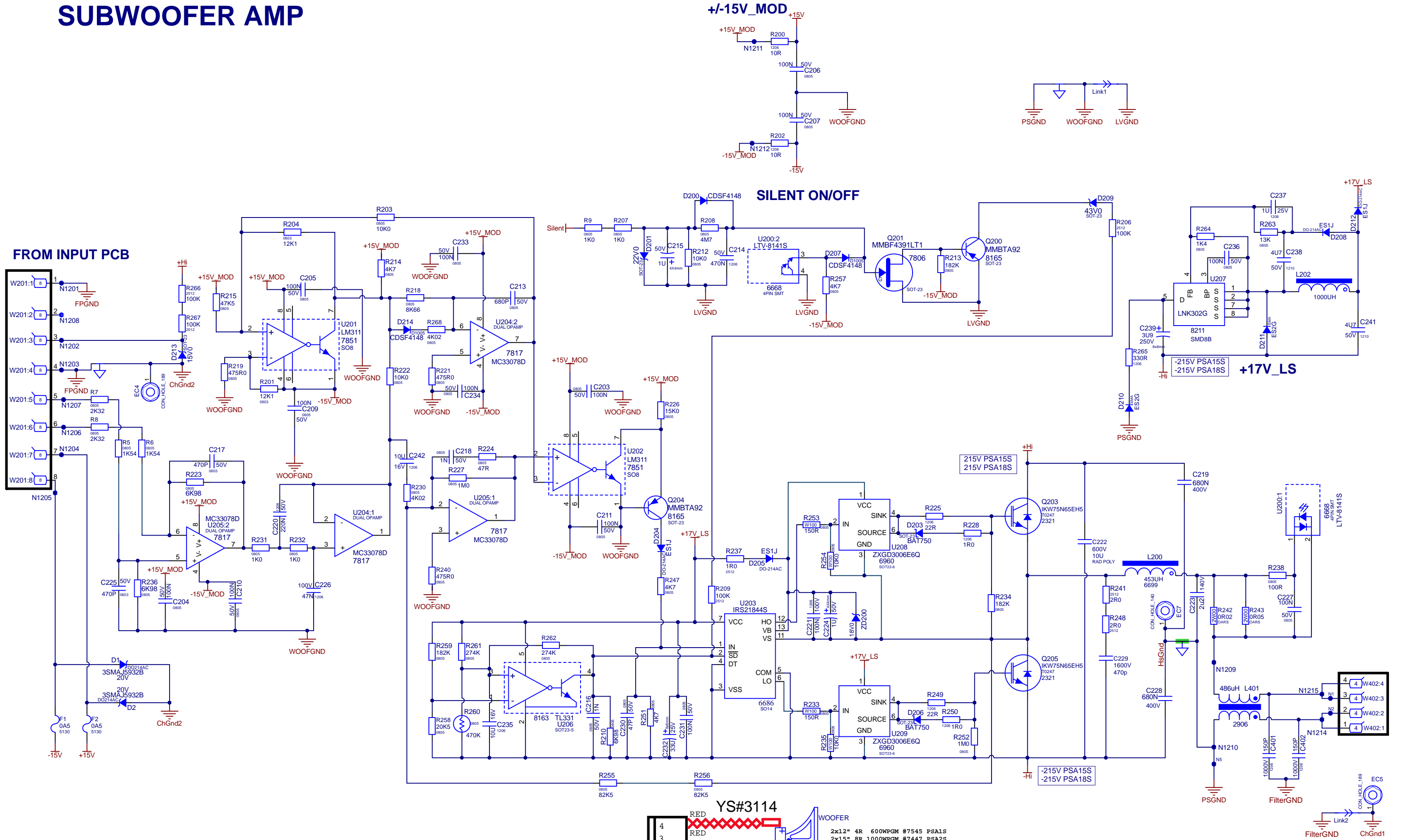

**YS#3114**

|       |    |          |       |       |
|-------|----|----------|-------|-------|
| 2x12" | 4R | 600WPGM  | #7545 | PSA1S |
| 2x15" | 8R | 1000WPGM | #7447 | PSA2S |
| 1x12" | 4R | 2800WPGM | #7437 | ES12P |
| 1x15" | 4R | 2800WPGM | #7470 | ES15P |
| 1x18" | 6R | 1200WPGM | #7420 | ES18P |
| 1x21" | 4R | 3000WPGM | #7500 | ES21P |

# DESIGN HISTORY AND INFORMATION

## CHANGE HISTORY

| #  | DATE        | VER# | PC# | DESCRIPTION OF CHANGE   |
|----|-------------|------|-----|-------------------------|
| 1  | 27-Feb-2025 | V01  | .   | Released for Production |
| 2  | .           | .    | .   | .                       |
| 3  | .           | .    | .   | .                       |
| 4  | .           | .    | .   | .                       |
| 5  | .           | .    | .   | .                       |
| 6  | .           | .    | .   | .                       |
| 7  | .           | .    | .   | .                       |
| 8  | .           | .    | .   | .                       |
| 9  | .           | .    | .   | .                       |
| 10 | .           | .    | .   | .                       |
| 11 | .           | .    | .   | .                       |
| 12 | .           | .    | .   | .                       |
| 13 | .           | .    | .   | .                       |

| #  | DATE | VER# | PC# | DESCRIPTION OF CHANGE |
|----|------|------|-----|-----------------------|
| 1  | .    | .    | .   | .                     |
| 2  | .    | .    | .   | .                     |
| 3  | .    | .    | .   | .                     |
| 4  | .    | .    | .   | .                     |
| 5  | .    | .    | .   | .                     |
| 6  | .    | .    | .   | .                     |
| 7  | .    | .    | .   | .                     |
| 8  | .    | .    | .   | .                     |
| 9  | .    | .    | .   | .                     |
| 10 | .    | .    | .   | .                     |
| 11 | .    | .    | .   | .                     |
| 12 | .    | .    | .   | .                     |
| 13 | .    | .    | .   | .                     |

| #  | DATE | VER# | PC# | DESCRIPTION OF CHANGE |
|----|------|------|-----|-----------------------|
| 1  | .    | .    | .   | .                     |
| 2  | .    | .    | .   | .                     |
| 3  | .    | .    | .   | .                     |
| 4  | .    | .    | .   | .                     |
| 5  | .    | .    | .   | .                     |
| 6  | .    | .    | .   | .                     |
| 7  | .    | .    | .   | .                     |
| 8  | .    | .    | .   | .                     |
| 9  | .    | .    | .   | .                     |
| 10 | .    | .    | .   | .                     |
| 11 | .    | .    | .   | .                     |
| 12 | .    | .    | .   | .                     |
| 13 | .    | .    | .   | .                     |

## POTENTIOMETERS AND KNOBS

## PINOUT DIAGRAMS

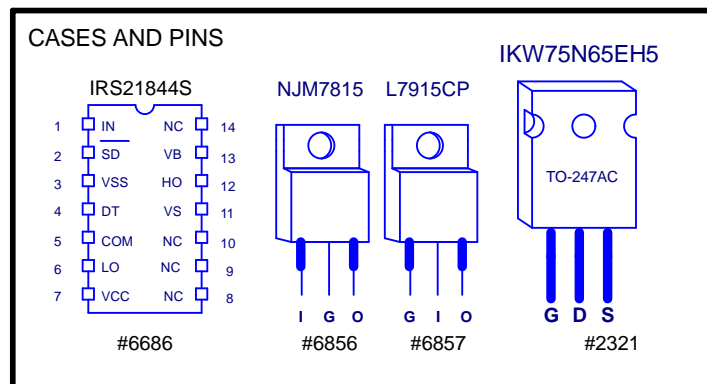

TO INPUT BOARD  
W201

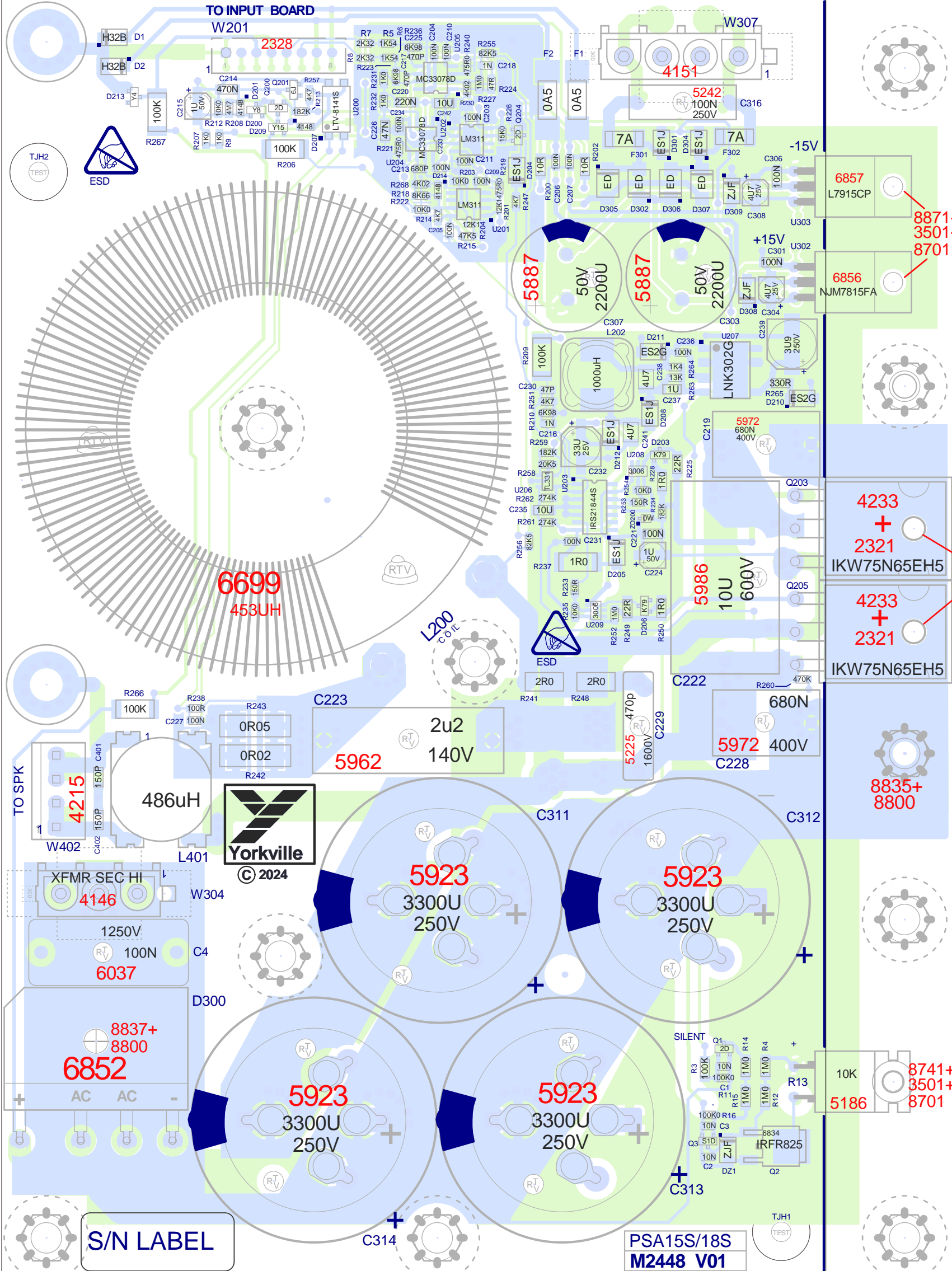

8871+  
3501+  
8701

4233  
+  
2321  
IKW75N65EH5  
8902+  
8485+  
8701

8835+  
8800

Z1963

8741+  
3501+  
8701

TO SPK

S/N LABEL

PSA15S/18S  
M2448 V01

M2448 V01 PSA15S/18S

Dimension: 100mmx225mm (11.8x9.0 inches)

# PCB ASSEMBLY DOCUMENTATION

## MOUNTING HARDWARE & INSTRUCTIONS FOR HEAT SPREADER Z1963:

PIC 1

1. Secure Heatsink Z1963 to pcb with screw YS# 8835 and nut YS# 8800 shown in PIC 1
2. Install all devices on Heat Spreader Z1963 as shown in pictures below.
3. Install #8800 and #8835 for grounding. Nut up.

After Wave:

1. RTV all tall caps and under parts where indicated.
2. Separate pcb from panel with appropriate tools.

- YS#: Z1963  
DESC: HEAT SPREADER
- YS#: 8800  
DESC: 6-32 KEPS NUT
- YS#: 8835  
DESC: 6-32X1/2 PAN  
INSERT FROM BOTTOM

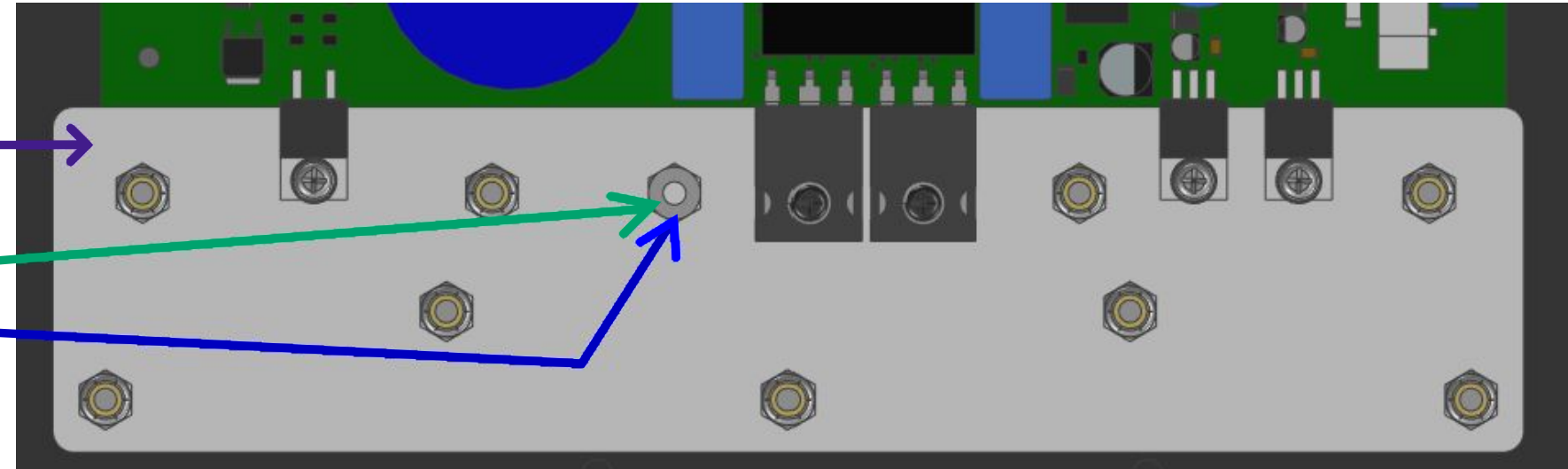

## MOUNTING HARDWARE FOR Q203/Q205

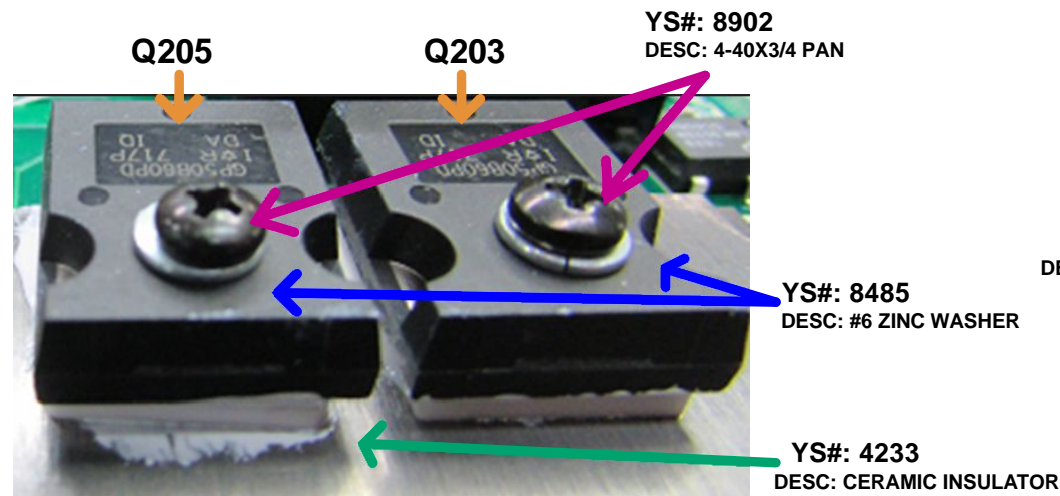

**ADD GOOP ON BOTH SIDES OF CERAMIC INSULATORS ← IMPORTANT!**

## MOUNTING HARDWARE FOR U302/U303

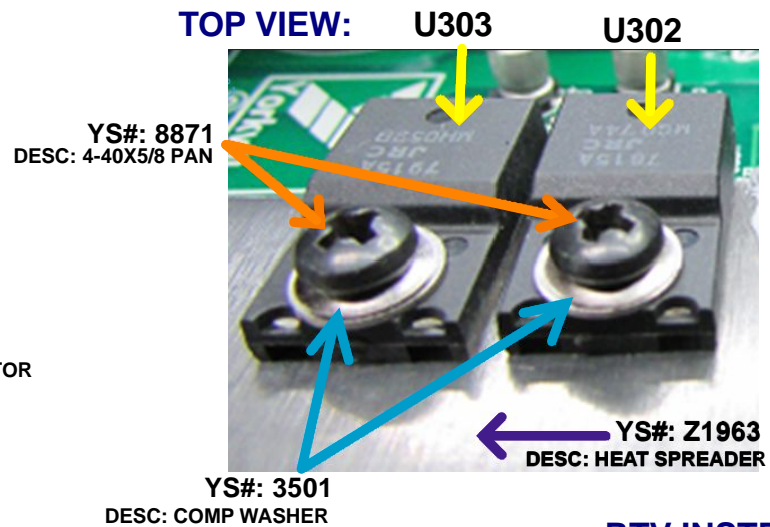

## BOTTOM MTG HARDWARE FOR U302/U303 and Q203/Q205

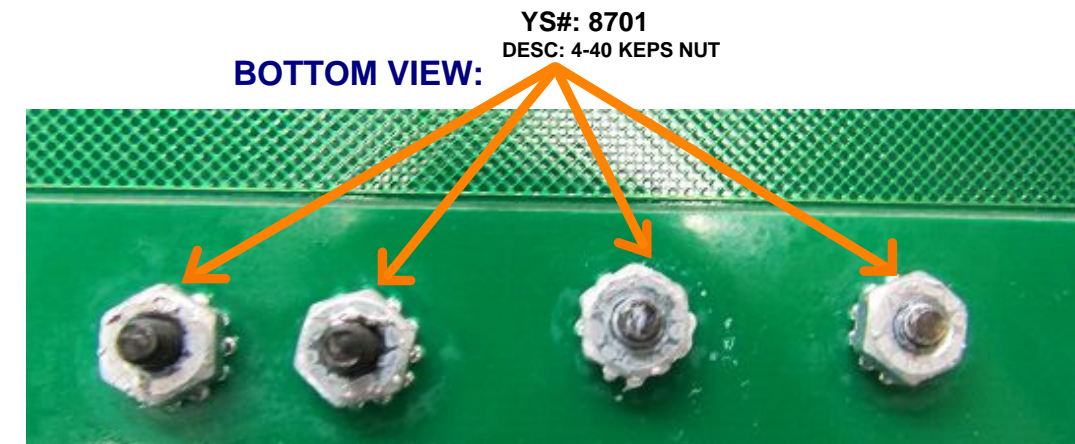

## MOUNTING HARDWARE FOR D300:

TOP VIEW:

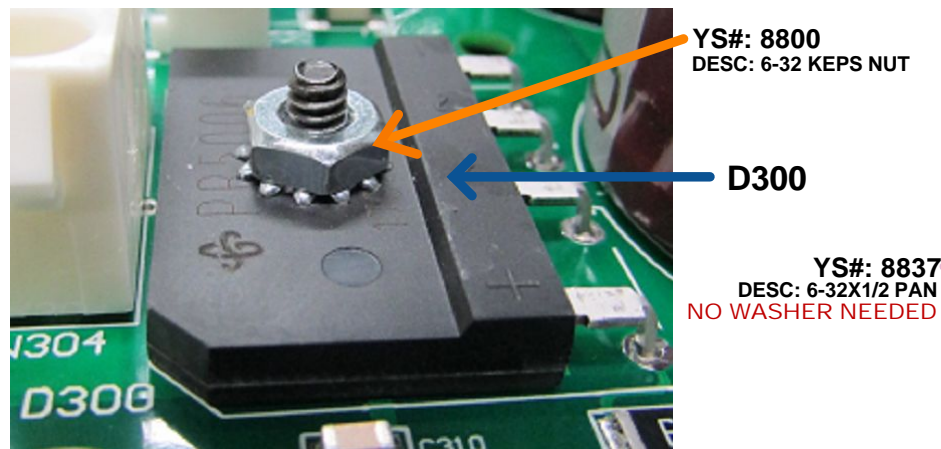

**Clip all 4 leads short on D300:**

BOTTOM VIEW:

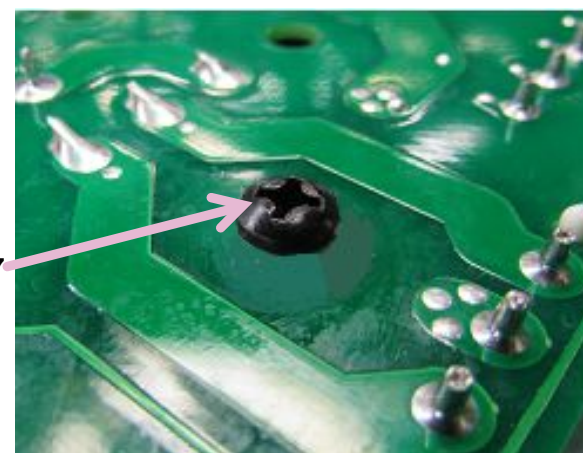

## RTV INSTRUCTIONS:

ADD RTV BETWEEN:  
C311, C312, C313 and C314 AFTER WAVE  
SOLDER

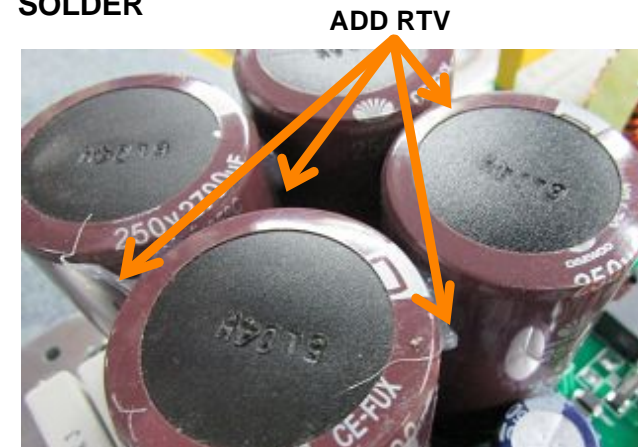

## MOUNTING HARDWARE FOR R13

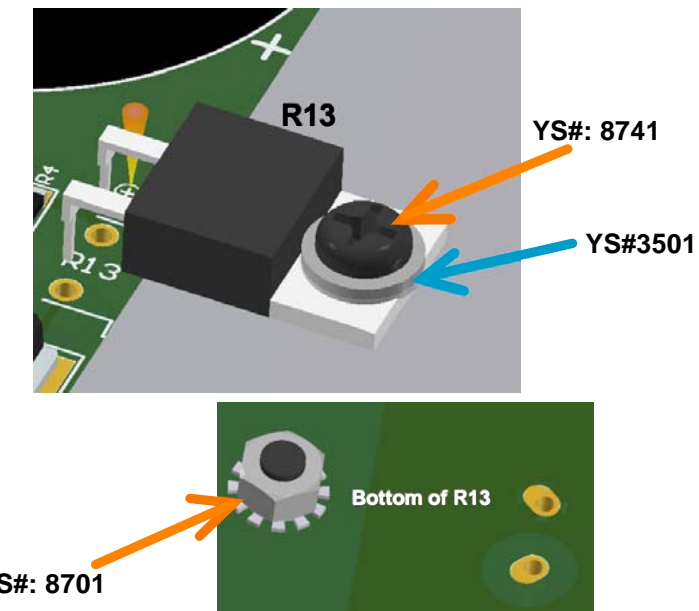

# DESIGN HISTORY AND INFORMATION

## CHANGE HISTORY

| #  | DATE        | VER# | PC# | DESCRIPTION OF CHANGE   |
|----|-------------|------|-----|-------------------------|
| 1  | 27-Feb-2025 | V01  | .   | Released for Production |
| 2  | .           | .    | .   | .                       |
| 3  | .           | .    | .   | .                       |
| 4  | .           | .    | .   | .                       |
| 5  | .           | .    | .   | .                       |
| 6  | .           | .    | .   | .                       |
| 7  | .           | .    | .   | .                       |
| 8  | .           | .    | .   | .                       |
| 9  | .           | .    | .   | .                       |
| 10 | .           | .    | .   | .                       |
| 11 | .           | .    | .   | .                       |
| 12 | .           | .    | .   | .                       |
| 13 | .           | .    | .   | .                       |

| #  | DATE | VER# | PC# | DESCRIPTION OF CHANGE |
|----|------|------|-----|-----------------------|
| 1  | .    | .    | .   | .                     |
| 2  | .    | .    | .   | .                     |
| 3  | .    | .    | .   | .                     |
| 4  | .    | .    | .   | .                     |
| 5  | .    | .    | .   | .                     |
| 6  | .    | .    | .   | .                     |
| 7  | .    | .    | .   | .                     |
| 8  | .    | .    | .   | .                     |
| 9  | .    | .    | .   | .                     |
| 10 | .    | .    | .   | .                     |
| 11 | .    | .    | .   | .                     |
| 12 | .    | .    | .   | .                     |
| 13 | .    | .    | .   | .                     |

  

| #  | DATE | VER# | PC# | DESCRIPTION OF CHANGE |
|----|------|------|-----|-----------------------|
| 1  | .    | .    | .   | .                     |
| 2  | .    | .    | .   | .                     |
| 3  | .    | .    | .   | .                     |
| 4  | .    | .    | .   | .                     |
| 5  | .    | .    | .   | .                     |
| 6  | .    | .    | .   | .                     |
| 7  | .    | .    | .   | .                     |
| 8  | .    | .    | .   | .                     |
| 9  | .    | .    | .   | .                     |
| 10 | .    | .    | .   | .                     |
| 11 | .    | .    | .   | .                     |
| 12 | .    | .    | .   | .                     |
| 13 | .    | .    | .   | .                     |

## POTENTIOMETERS AND KNOBS

## PINOUT DIAGRAMS

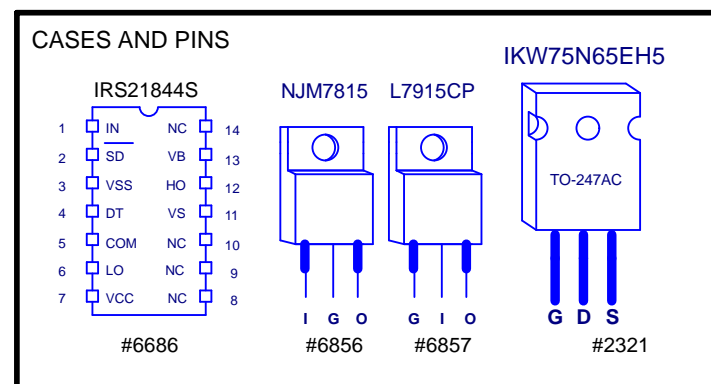

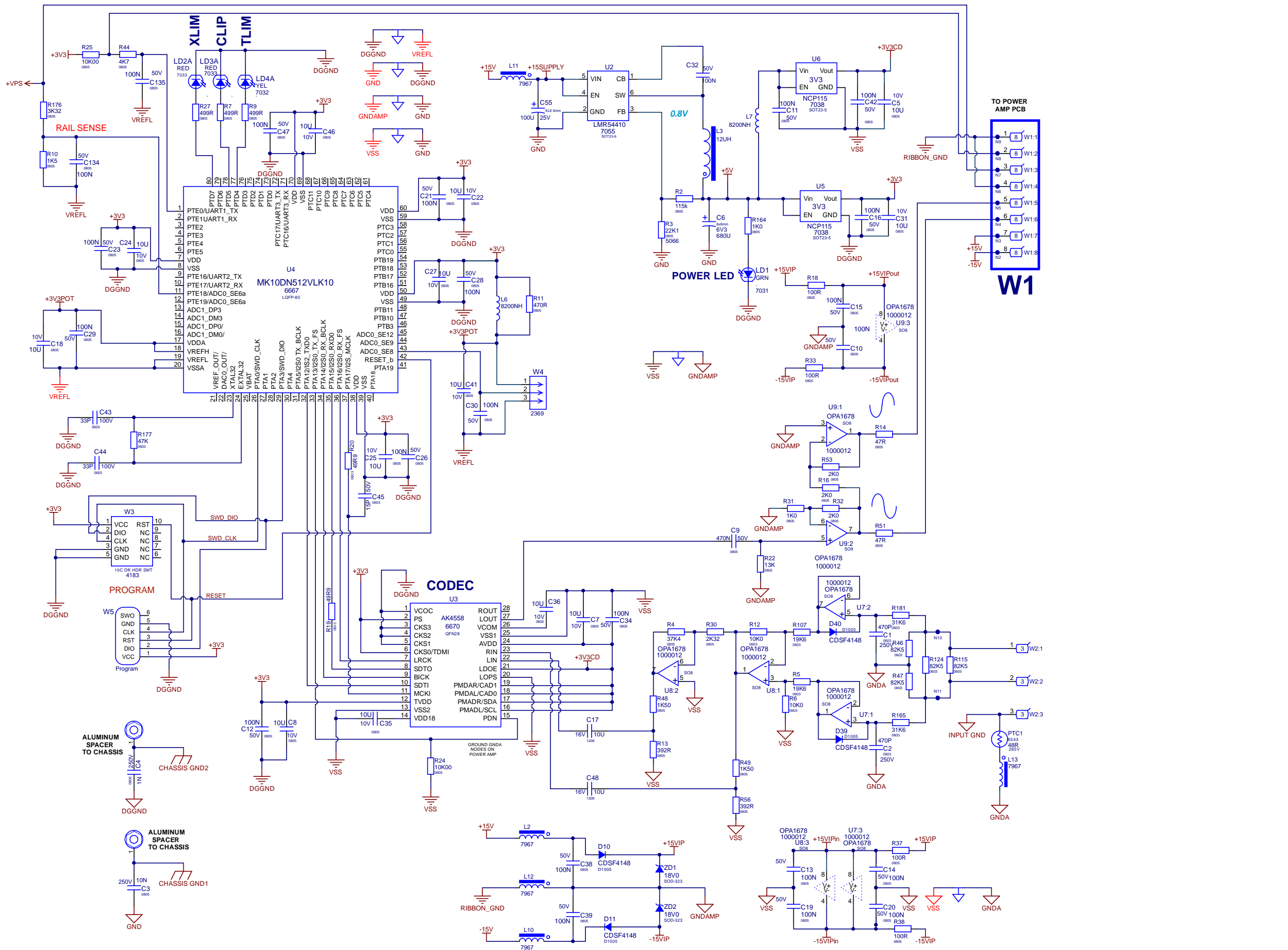





S/N LABEL

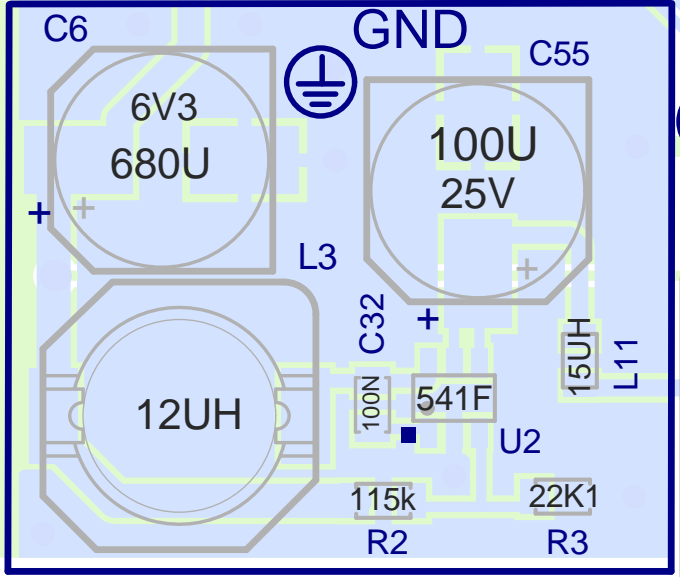

M2449 V01

PSA15S/ PSA15S\_18S

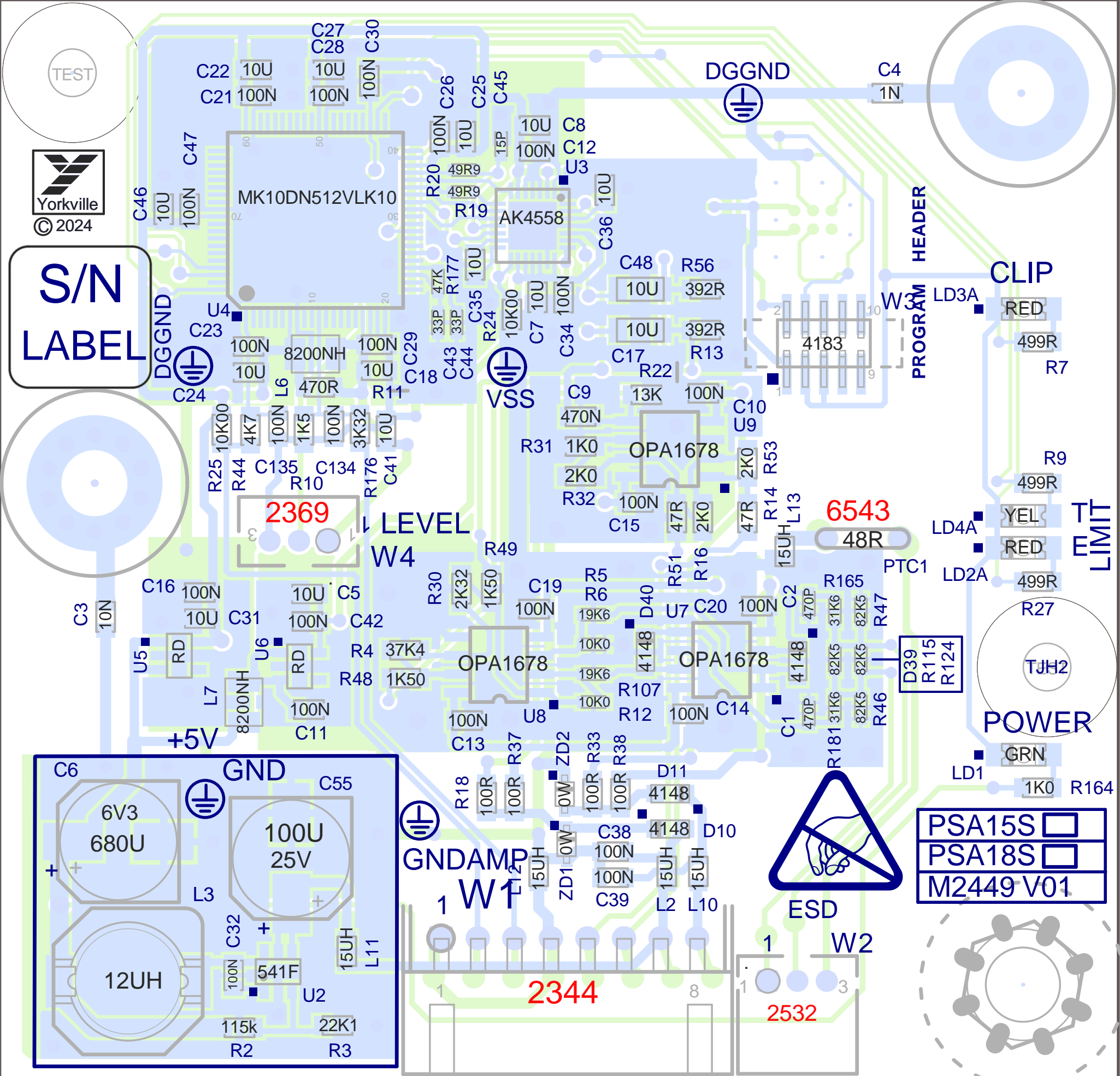

|           |                          |
|-----------|--------------------------|
| PSA15S    | <input type="checkbox"/> |
| PSA18S    | <input type="checkbox"/> |
| M2449 V01 |                          |

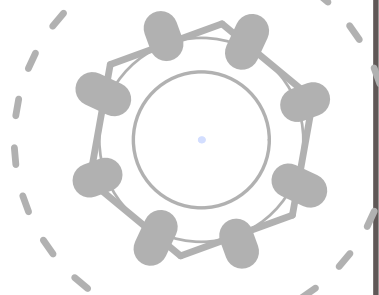

# PCB ASSEMBLY DOCUMENTATION

## PRODUCTION NOTES

1. AFTER WAVE INSPECT BOARD FOR ANY SHORTS AND SOLDER DEFECTS.
2. USE PIZZA CUTTER OR APPROPRIATE TOOL TO SEPARATE BOARD FROM PANEL.
3. PUT A INDELIBLE MARK BESIDE PRODUCT NAME THAT MATCHES THE PROGRAM FOR THE PRODUCT.

## PCB HARDWARE





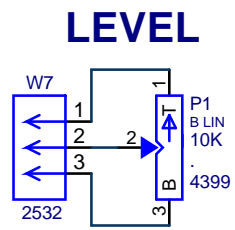
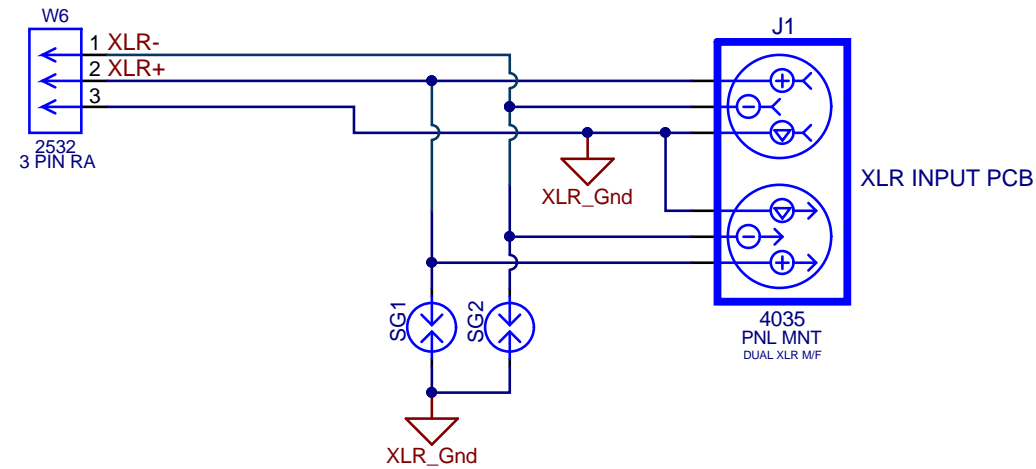

# AC FILTER

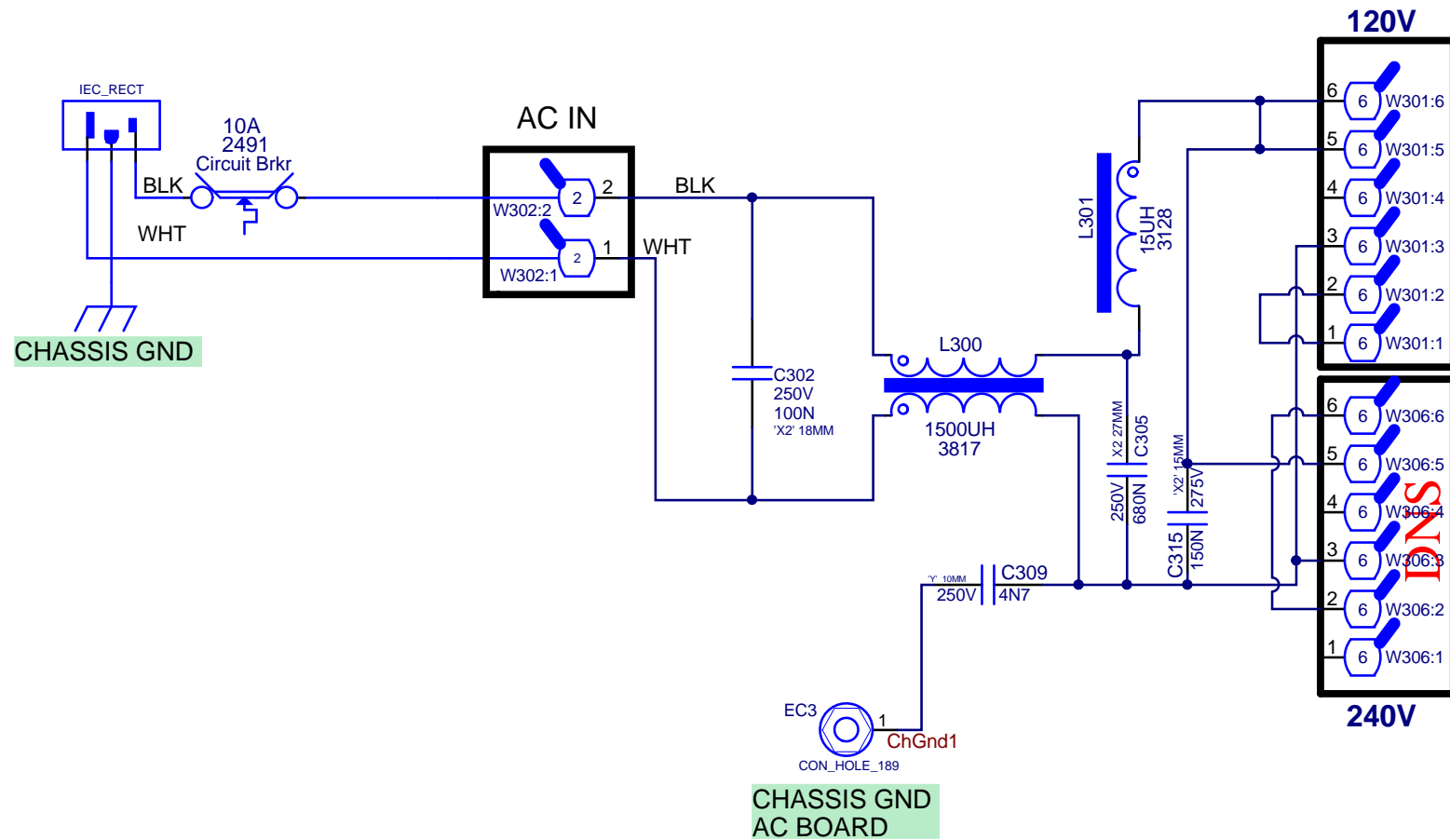

|                               |           |                        |              |
|-------------------------------|-----------|------------------------|--------------|
| Section: <b>AC FILTER</b>     |           |                        |              |
| Product(s): <b>PSA15S/18S</b> |           |                        |              |
| PCB#: M2450                   | Rev#: V01 | Eng: gg                | Sheet 1 Of 2 |
| Modified: 2025-03-04          |           | File: AC_Filter.SCHDOC |              |



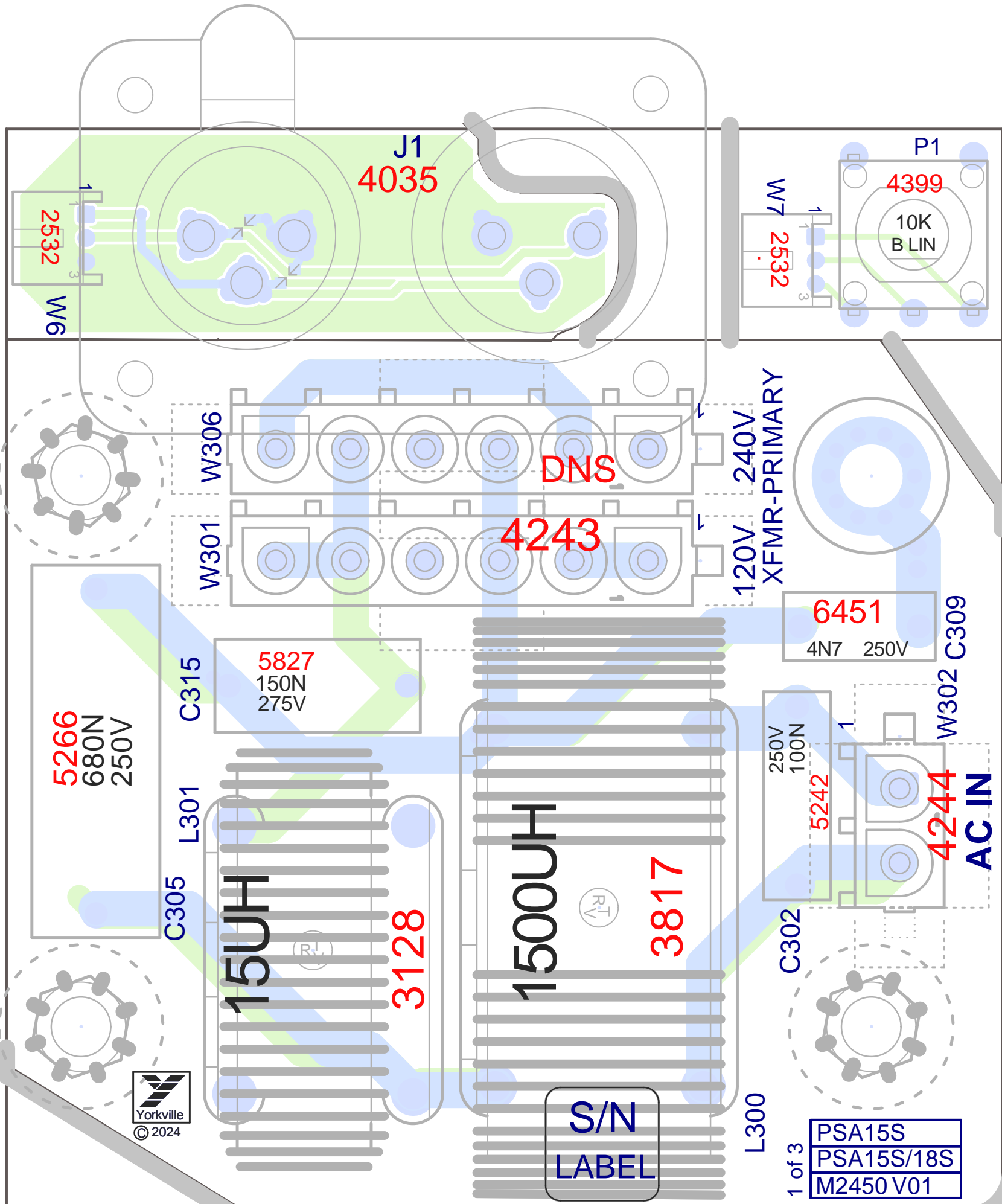

**M2450 V01 PSA15S/18S**



**S/N LABEL**

1 of 3  
**PSA15S**  
**PSA15S/18S**  
**M2450 V01**

**5266**  
 680N  
 250V

**5827**  
 150N  
 275V

**3128**

**1500UH**  
 (RT)  
**3817**

250V  
 100N  
**5242**

**6451**  
 4N7 250V

**4244**  
**AC IN**

**4243**

**DNS**

**J1**  
**4035**

**P1**  
**4399**

10K  
 B LIN

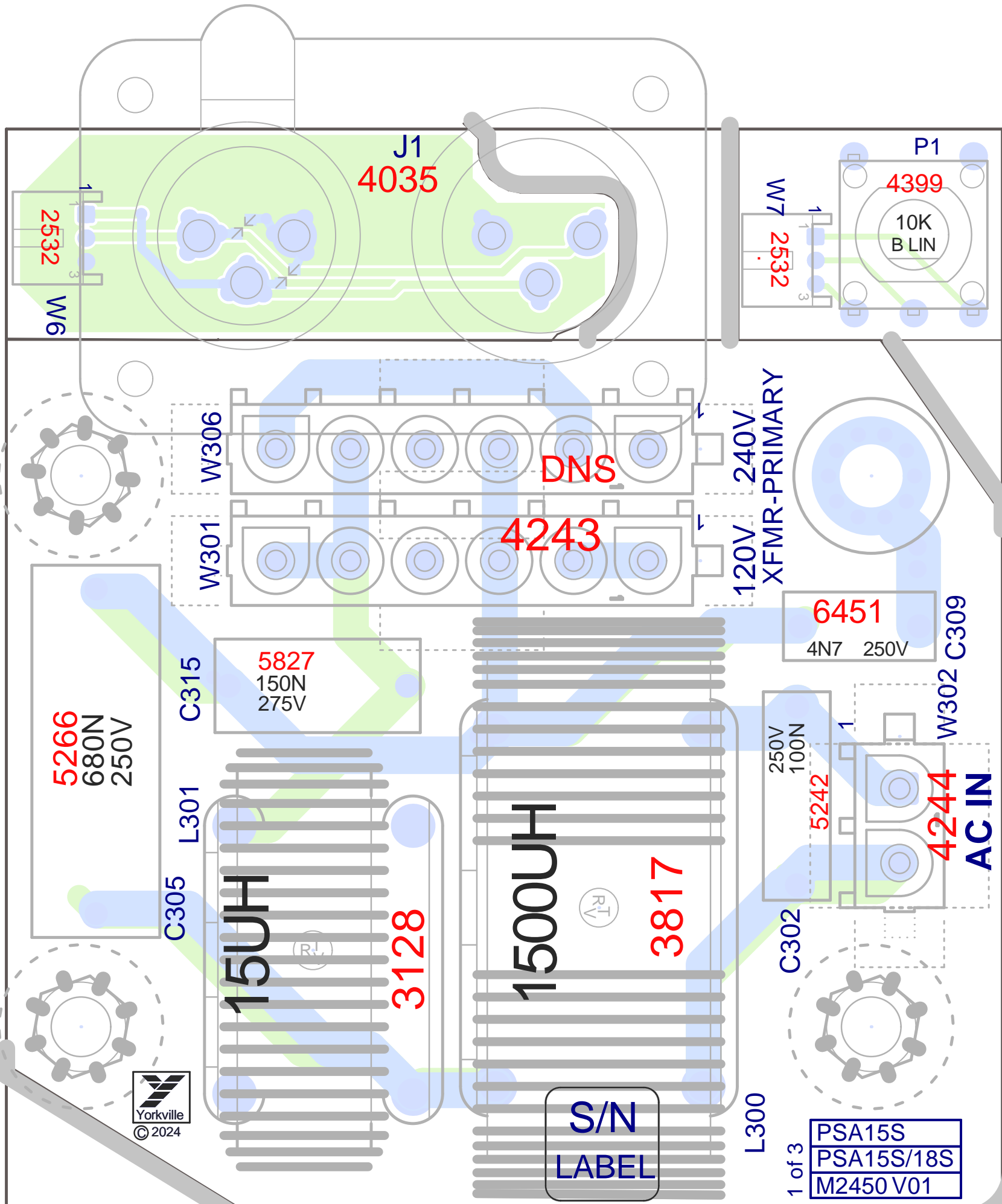

# PCB ASSEMBLY DOCUMENTATION

## SPECIAL PRODUCTION NOTES

### BEFORE WAVE:

1. USE PROVIDED JIG TO STABILIZE J1 (YS# 4035) BEFORE PLACING BOARD IN WAVE SOLDER MACHINE.

### AFTER WAVE:

1. INSPECT BOARD FOR ANY SHORTS AND SOLDER DEFECTS.
2. USE PIZZA CUTTER OR APPROPRIATE TOOL TO SEPARATE BOARD FROM PANEL.

## PCB HARDWARE





# PARALINE SERIES

## PSA Series Powered Subwoofers

### Level Control

This sets the output level of the enclosure so you can adjust the amount of bass reinforcement and balance volume across the entire system. When setting up, we recommend starting with the Level control at 12:00.

### Main In / Main Out Jacks

The input and output jacks are connected in parallel to link multiple cabinets that share a single audio source. Signal will pass from the input to the output even when the subwoofer is powered off.

### Protection (LEDs)

Onboard DSP protects the subwoofer against clipping, over-power, and over-exursion. Status LEDs next to the Level control will illuminate to indicate clipping and limiting. The clipping indicator may illuminate before distortion is audible. At high power levels, the internal limiter may effectively override the Level control

### Stand Mounting Adapter

The enclosures feature a 35 mm (1 3/8") adapter for use with the Yorkville SW-TUBEHD mounting pole. A maximum of two top enclosures can be used together on the SW-TUBEHD with a subwoofer as the base.

*WARNING: The subwoofer must be on a flat, level surface when used as a base. Please carefully observe all guidance regarding weight limits and the maximum size or number of enclosures that can be mounted on the base and pole.*

### Flying Rig

Please refer to the supplemental Rigging Manual.

### IP54 Rating

PSA15S and PSA18S enclosures have an IP54 rating, meaning they are rated for outdoor use and protected against dust and splashing water. Please note that the enclosures are not protected against high-pressure water jets or submersion in water. For safe outdoor use, any powerCON® TRUE1 or XLR connectors must be fully inserted, and the protective covers or gaskets for unused connectors must be seated correctly.

*Use Neutrik-branded connectors to maintain the IP54 rating. Paraline enclosures should only be used in ambient temperatures between 0° and 45° Celsius (32° to 113° Fahrenheit).*

### Power

The PSA15S and PS18S have locking powerCON® TRUE1 connectors for power input and pass-through, so you can daisy-chain power between multiple units.

A maximum of two PSA15S or PSA18S can be connected on a single 15A circuit. If using with top boxes on a 15A circuit, the total amperage should not exceed 12A.

The power connector is rated for outdoor use and allows AC line voltage to be connected or disconnected while live and delivering power to the enclosure. It is IP54 rated when a power cable is connected or when the cap is closed. The caps are spring-loaded to automatically cover the connector when the power cable is disconnected.

*When installing equipment outdoors, the mains receptacle should follow outdoor installation code and feature GFCI (RCD) protection.*

To get the full Owner's Manual please visit our website at

<http://www.yorkville.com/manuals/> or, if you need a printed version call 905-837-8777

**REAL Gear.**  
**REAL People.**



Canada Voice: 905-837-8431  
Fax: 905-839-5776

U.S.A. Voice: 716-297-2920  
Fax: 716-297-3639

[www.yorkville.com](http://www.yorkville.com)

Yorkville Sound  
550 Granite Court  
Pickering, Ontario  
L1W-3Y8 CANADA

Yorkville Sound Inc.  
4625 Witmer Industrial Estate  
Niagara Falls, New York  
14305 USA

Printed In CANADA

QuickStart-PSA15S-PSA18S-00-1v3 • YS#QSTARTPSAS • January 6, 2026

# PARALINE SERIES

## Subwoofers Amplifiés de la Série PSA

### Commande de Gain

Cette commande règle le niveau de sortie du caisson afin de vous permettre d'ajuster le niveau de renforcement des basses et d'équilibrer le volume sur l'ensemble du système. Lors de la configuration, nous vous recommandons de commencer par régler le niveau à 12h00.

### Prises d'Entrée Principale / de Sortie Principale

Les prises d'entrée et de sortie sont connectées en parallèle pour relier plusieurs enceintes qui partagent la même source audio. Le signal passe de l'entrée à la sortie même lorsque le caisson de basses est éteint.

### Protection (DELS)

Le DSP intégré protège le caisson de basses contre l'écrêtage, la surpuissance et les déplacements excessifs. Les voyants d'état situés à côté du contrôle de niveau s'allument pour indiquer l'écrêtage et la limitation. L'indicateur d'écrêtage peut s'allumer avant que la distorsion ne soit audible. À puissance élevée, le limiteur interne peut neutraliser le contrôle de niveau.

### Adaptateur de Montage Sur Pied

Les enceintes sont équipées d'un adaptateur de 35 mm (1 3/8") pour une utilisation avec le poteau de montage Yorkville SW-TUBEHD. Un maximum de deux enceintes Paraline peuvent être utilisées ensemble sur le SW-TUBEHD, avec un caisson de basses comme base.

*AVERTISSEMENT : Toute base doit être posée sur une surface plane et horizontale. Veuillez respecter scrupuleusement les consignes concernant les limites de poids et la taille ou le nombre maximal d'enceintes pouvant être montées sur la base et le poteau.*

### Matériel de Suspension

Veuillez-vous référer au manuel de montage supplémentaire.

### Indice de Protection IP54

Les boîtiers PSA15S et PSA18S sont classés IP54, ce qui signifie qu'ils sont conçus pour une utilisation en extérieur et protégés contre la poussière et les projections d'eau. Veuillez noter que les boîtiers ne sont pas protégés contre les jets d'eau à haute pression ni contre l'immersion. Pour une utilisation en extérieur en toute sécurité, tous les connecteurs powerCON® TRUE1 ou XLR doivent être complètement insérés et les caches ou joints de protection des connecteurs non utilisés doivent être correctement installés.

*Utilisez des connecteurs Neutrik pour maintenir l'indice IP54.*

*Les boîtiers Paraline doivent être utilisés uniquement à des températures ambiantes comprises entre 0 et 45 °C (32 et 113 °F).*

### Alimentation CA

Les PSA15S et PSA18S sont équipés de connecteurs powerCON® TRUE1 verrouillables pour l'entrée et la sortie d'alimentation, permettant de connecter plusieurs unités en série. Chaque caisson de basses est fourni avec un câble powerCON® TRUE1 de 12 pieds. Pour connecter plusieurs unités, vous pouvez utiliser un câble plus court, comme le Yorkville PSACABLELOOP.

Un maximum de deux PSA15S ou PSA18S peuvent être connectés sur un même circuit de 15 A. En cas d'utilisation avec des boîtiers supérieurs sur un circuit de 15 A, l'ampérage total combiné ne doit pas dépasser 12 A.

Le connecteur d'alimentation est conçu pour une utilisation en extérieur et permet de connecter ou de déconnecter la tension secteur CA sous tension et d'alimenter le boîtier. Il est certifié IP54 lorsqu'un câble d'alimentation est connecté ou lorsque le capuchon est fermé. Les capuchons sont à ressort pour recouvrir automatiquement le connecteur lorsque le câble d'alimentation est déconnecté.

Lors de l'installation d'équipements à l'extérieur, la prise secteur doit respecter le code d'installation extérieur et être dotée d'une protection GFCI.

Pour obtenir le manuel de utilisateur visitez notre site Web à <http://www.yorkville.com/manuals/> ou, si vous avez besoin d'une version imprimée appelez-nous au 905-837-8777

**REAL Gear.**  
**REAL People.**



Canada Voice: 905-837-8431  
Fax: 905-839-5776

U.S.A. Voice: 716-297-2920  
Fax: 716-297-3639

[www.yorkville.com](http://www.yorkville.com)

Yorkville Sound  
550 Granite Court  
Pickering, Ontario  
L1W-3Y8 CANADA

Yorkville Sound Inc.  
4625 Witmer Industrial Estate  
Niagara Falls, New York  
14305 USA



**Yorkville Sound**

550 Granite Court  
Pickering, Ontario  
Canada L1W 3Y8

Auto Attend: (905) 837-8550

Fax: (905) 839-5776

[www.yorkville.com](http://www.yorkville.com)

---